



## Mini-Storage Installation Guide



REGENCY STORAGE SYSTEMS  
10390 Bradford Road - Suite 140  
Littleton, CO 80127  
800-292-0111

## INTRODUCTION

### *Thank you for choosing our self-storage system*

#### Our Building Packages Offer

- Simple and Fast Construction
  - Construction so simple a small crew equipped with stepladders, screw guns, and hand tools can erect the entire building.
  - All framing members identified with piecemark and length.
- Quick and Accurate Delivery
  - Our Quick Quote-to-Complete self-storage packages come with everything you'll need to erect your mini storage.
  - We handle everything including the design, manufacture and delivery of these complete self-storage building packages.
  - You can expect a quality product delivered to you, on time, and at a great value.

#### Standard Product Descriptions

- 8'-6" eave height
- 1/2:12 roof slope
- Panels & Trim –
  - Roof panels - 26 gauge galvalume "R" panel with 20 year warranty
  - Wall panels - 26 gauge painted "R" panel with 40 year limited warranty
  - Interior partition panels - 29 gauge galvalume
  - Trim package - 26 gauge painted simple eave trim, rake trim, mullion cover, door jamb, head trim, and outside corners
- Framing - 16 gauge red oxide steel
- Base condition –
  - 14 gauge base clips at interior columns
  - Base Angle at sheeted walls
  - Base Channel at door mullions and jambs
- Accessories –
  - Inside closures under roof panels at low eave
  - Outside closures between rake trim and endwall panels
  - 7/8" Butyl tape for roof panel laps and top/bottom of inside closures
- Fasteners –
  - 1" Self Drilling Tek fastener for framing
  - 1 1/4" and 7/8" Self Drilling Tek fastener with washer for exterior panels and trim
  - 1 1/4" and 7/8" Long Life Zac fastener with washer for roof panels
  - 1/2" x 2 3/4" Wedge Anchors for base conditions
- Complete set of erection drawings

#### Available Options

- |                                       |   |
|---------------------------------------|---|
| • Gutter and downspouts               | • Engineer stamped drawings                   |
| • Base Channel or Angle               | • Eave heights available from 8'-6" to 16'-0" |
| • Standing seam roof systems          | • Boat/RV storage units                       |
| • Complete insulation packages        | • Climate controlled units                    |
| • Roll up doors with 26 gauge curtain | • 19 color options available                  |

*If you should have any questions or concerns during the construction of your mini-storage, please give us a call.*

## GENERAL INFORMATION

**Please Note:** Jobsite safety instructions, equipment, and conditions are the responsibility of the builder/contractor. The following are a few helpful reminders and are not meant to replace the builder/contractor's established safety program.

### **Safety Tips**

#### Guidelines

- Always make safety your number one priority on the jobsite.
- Refer to local, state, and federal safety and health standards to help insure worker safety.
- Emergency telephone numbers, location of first aid stations, and emergency procedures should be shared with all employees.

#### Equipment

- Tools and equipment should only be used for the purpose they were intended.
- Maintain a safe position and sure footing when using tools or equipment.
- Never overload electrical outlets and verify they are equipped with a breaker.
- Do not drag power cords over sharp edges such as panel edges.
- Crane and lift swing range should be marked as a hazardous area.

#### Personal Protection Equipment

- Always use gloves when handling sheeting.
- Wear safety goggles and gloves when using power tools.
- Wear protective mask and gloves when handling exposed insulation.
- Hardhats should be worn whenever there is a hazard of falling objects.

#### Jobsite

- Do not work in conditions of high winds, rain, snow or lightening.
- Watch out for power and gas lines while working.
- Unsecured roof panels may collapse. Do not stand within five feet of end of panel.
- Maintain an awareness of your location in relation to the roof edge.
- Rigid and blanket insulation will not support a worker.
- Clean spills immediately to prevent workers from slipping or falling.

### **Material Handling**

#### Delivery

- Verify the jobsite has adequate access prior to delivery of materials.
- Drivers have the authority to refuse delivery to any location they see as unsafe or inaccessible.
- Customer is responsible for any charges incurred if truck is detained for any reason.
- Customer is responsible for unloading of material.
- Material should be unloaded with a forklift or crane.
- Banding should never be used to lift bundles.
- Materials should be inventoried and checked for damage at time of delivery.
- Notify building supplier of damaged material within three (3) days after delivery.
- Care should be taken to avoid damaging material during unloading or staging.

#### Storage

- Jobsite storage shall be in a clean and dry area, out of direct contact with ground water.
- Protect bottom panel from direct contact with moisture, concrete, asphalt, gravel, or any corrosive materials.
- Material stored outside should be covered with a tarp and sloped for drainage.
- A plastic cover should not be used, as this may cause condensation to occur.
- Protect material against damage from traffic, high winds, or corrosive material.
- Do not stack bundles. If stacking is required, separate bundles with 2x6 boards to distribute load.
- Do not allow panels to buckle during handling. Do not pick up sheeting by the end of the panel or carry sheets in a flat position. Always carry sheets on edge or in a vertical position.
- Do not slide panels off the bundle. Rotate top sheet off bundle to vertical position.
- Avoid extended storage time. Check material periodically to make sure moisture has not made contact with material.

#### Details

- Review all erection drawings and installation guide prior to beginning work on project.
- If there is a conflict between project erection drawings and details in this manual, project erection drawings will take precedence.
- Customer is responsible for verification of applicable building codes and design loads, prior to production of erection drawings.

#### Cutting / Drilling

- A portable field shear or metal nibblers is the ideal method for cutting panels.
- We do not recommend saw cutting panels. If a power saw is used, turn panels upside down so hot shavings do not come into contact with painted surfaces.
- If metal shavings become imbedded in the paint surface, they will quickly rust.
- Panels should not be drilled while stacked. This will cause shavings to become imbedded in the paint surface.
- Panels should be thoroughly wiped of all filings on both sides of panel.

**PARTS LIST**

Framing

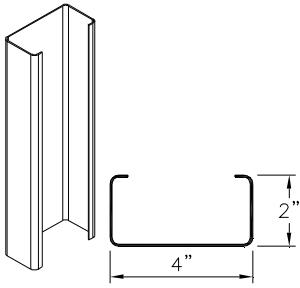

**Column / Door Header / Girt**  
Material: 16 Gauge  
Piecemark: C4 / DH / G

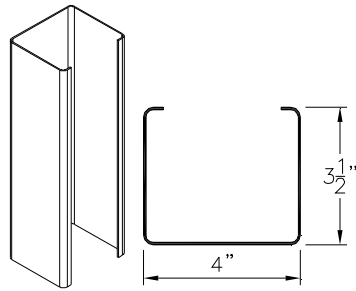

**Door Jamb**  
Material: 16 Gauge  
Piecemark: DJ

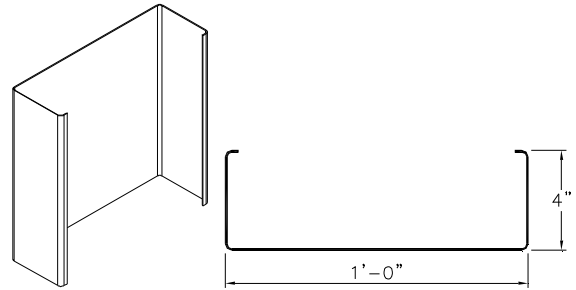

**One Piece Column**  
Material: 16 Gauge  
Piecemark: M

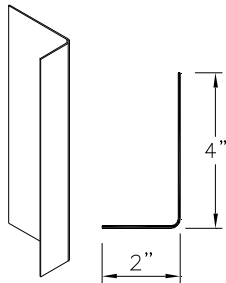

**Rake / Partition Angle**  
Material: 16 Gauge  
Piecemark: PA / RA

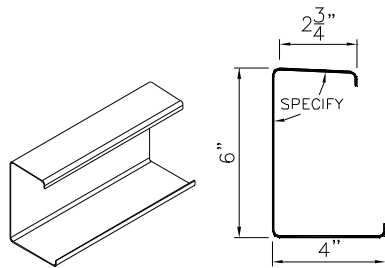

**Eave / Ridge Strut**  
Material: 16 Gauge  
Piecemark: ES / RS  
Note: Used at pitches > 1/2:12

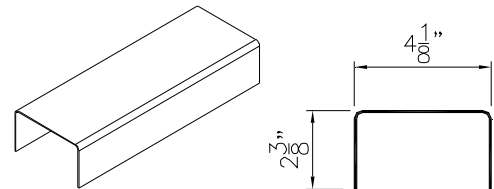

**Eave Channel**  
Material: 16 Gauge  
Piecemark: EC  
Note: Used at pitches ≤ 1/2:12

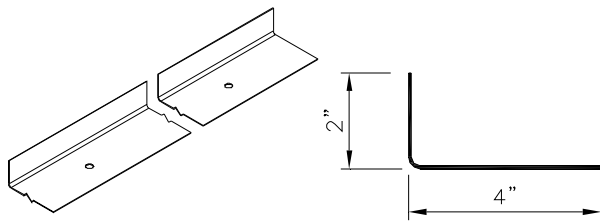

**Perimeter Angle**  
Material: 16 Gauge  
Piecemark: BA  
Note: Punched 6" From End & 5'-0" O.C.

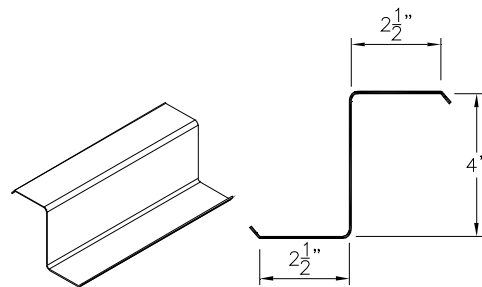

**Purlin**  
Material: 16 Gauge  
Piecemark: P4

Clips

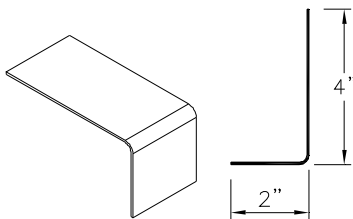

**Mini-Clip**  
Material: 16 Gauge  
Part Code: MC  
Note: Cut To 2" Length

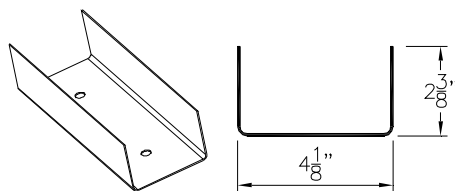

**Base Channel**  
Material: 16 Gauge  
Part Code: BC  
Note: 11 3/4" Channel - Punched 2" From Each End  
Note: 5 3/4" Channel - Punched 1" From Each End

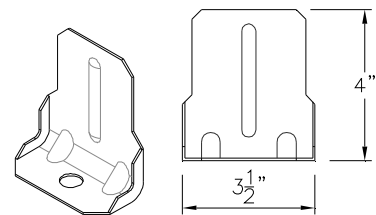

**Floor Base Clip**  
Material: 14 Gauge  
Part Code: FC

**PARTS LIST**

Panels

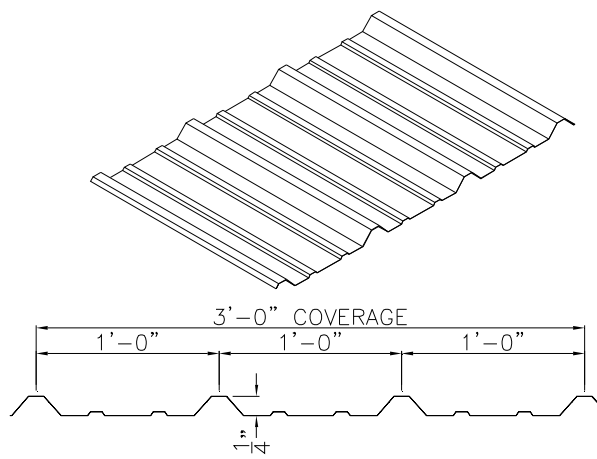

**R-Panel**  
Used at Roof and Walls  
Part Code: RW at Wall / RR at Roof

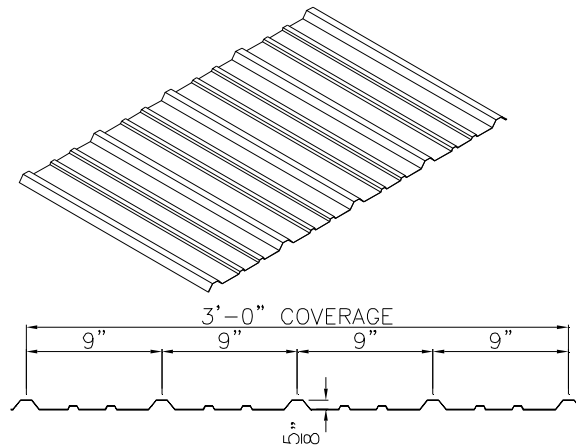

**Panel-Loc Panel**  
Used at Partitions  
Part Code: PL

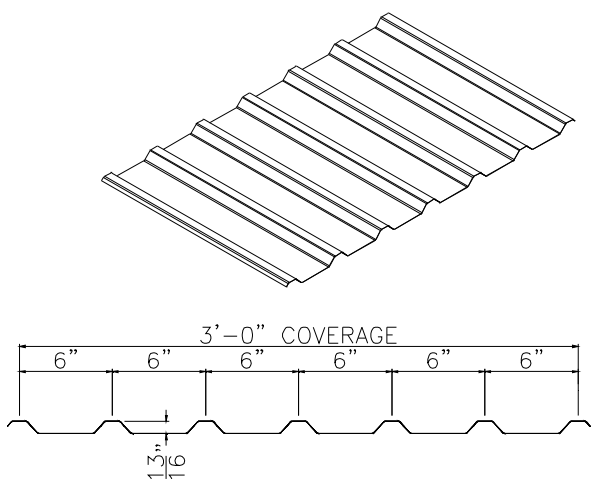

**M-Panel**  
Used at Partitions  
Part Code: ML

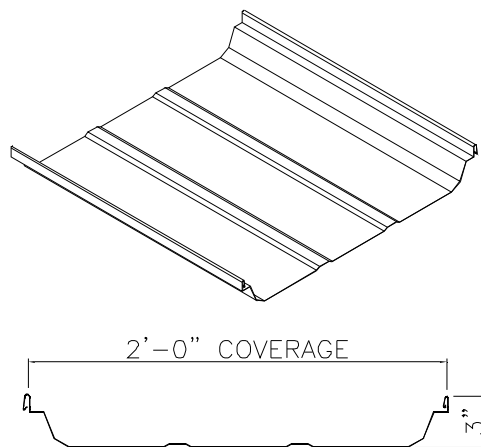

**Central-Loc / Central Seam Plus Panel**  
Used at SSR Roof  
Part Code: CL / CSP

Please refer to the SSR Installation Guide for specific information regarding the Central-Loc / Central Seam Plus Roofing System.

## PARTS LIST

### Trim

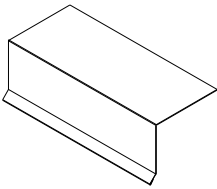

**Long Eave Trim**  
Part Code: EF  
Note: At Buildings Without Gutter

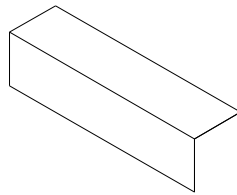

**3x3 Eave (Gutter Backer)**  
Part Code: EF  
Note: At Buildings With Gutter

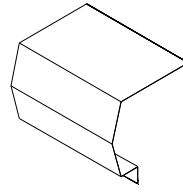

**High Side Eave**  
Part Code: HI  
Note: At Single Slope Buildings

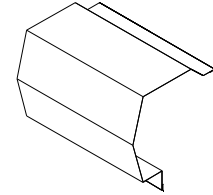

**Rake**  
Part Code: RA

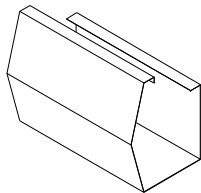

**Gutter**  
Part Code: GU

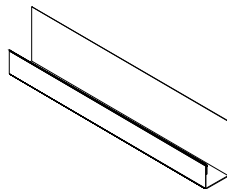

**Door Head Trim**  
Part Code: HE

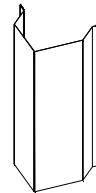

**Outside Corner**  
Part Code: OU

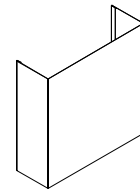

**Mullion Cover**  
Part Code: MC

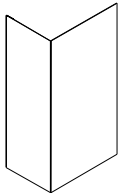

**Corner Mullion Cover**  
Part Code: CM



**Jamb Trim**  
Part Code: JA



**Jamb / Head Cover**  
Part Code: JC / HC



**Downspout w/ Kickout**  
Part Code: DK

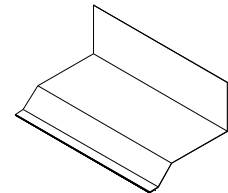

**Transition Trim**  
Part Code: TR  
Note: At Roof Step

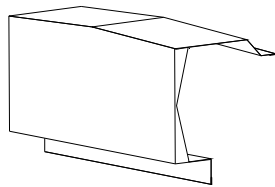

**Peak Box**  
Part Code: PBOX

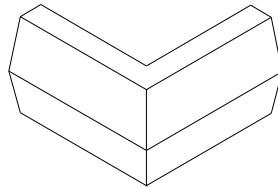

**Outside Corner Box**  
Part Code: OCB

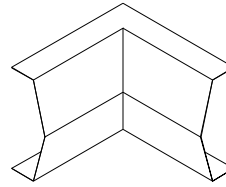

**Inside Corner Box**  
Part Code: ICB

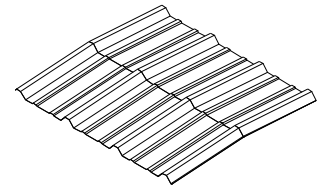

**Formed Ridge Cap**  
Part Code: FRC  
Note: Used at pitches > 1/2:12

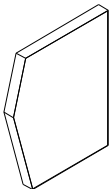

**Gutter End Cap**  
Part Code: GEND

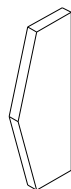

**Rake End Cap**  
Part Code: REND

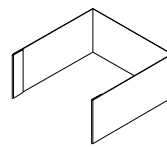

**Downspout Strap**  
Part Code: DSS

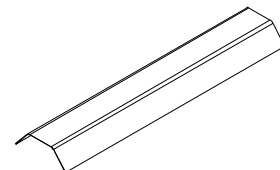

**Gutter Strap**  
Part Code: GS9

## PARTS LIST

### Fasteners

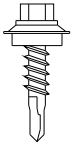

#14 -7/8" Self Drilling  
Tek With Washer  
Used For:  
-Wall Lap  
-Trim Lap

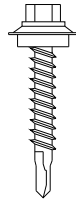

#12 -1 1/4" Self Drilling  
Tek With Washer  
Used For:  
-Wall Sheet Driller  
-Trim Driller

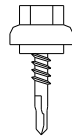

#14 -7/8" Self Drilling  
Zac With Washer  
Used For:  
-Roof Lap

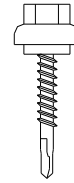

#12 -1 1/4" Self Drilling  
Zac With Washer  
Used For:  
-Roof Sheet Driller

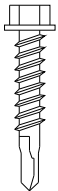

#12 -1" Self Drilling  
Tek (No Washer)  
Used For:  
-Framing  
-Partition Sheeting

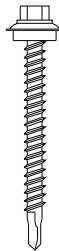

#12 -2" Self Drilling  
Tek With Washer  
Used For:  
-Partition Angle  
At Partition Crossing

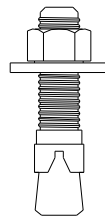

1/2" x 2 3/4" Wedge Anchor  
Used For:  
-Base Clip to Slab



Pop Rivet  
Used For:  
-Trim Lap  
-Downspout to Gutter  
-Outside Corner Box  
-Downspout Strap

### Closures

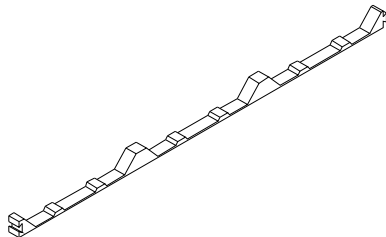

Inside Closure  
Part Code: CLIN  
Available with or without glue  
Used:  
Between Roof Panel and Eave Trim

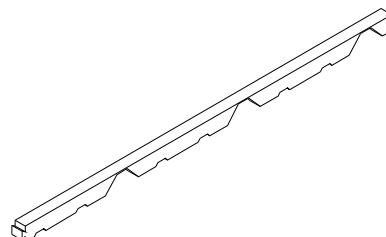

Outside Closure  
Part Code: CLOUT  
Available with or without glue  
Used:  
Between Rake Trim and Wall Panel  
Between High Side Eave Trim and Roof/Wall Panels

### Accessories

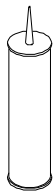

Geocel Sealant  
Part Code: GEOCEL  
Used:  
-Gutter Laps  
-Gutter to Downspout

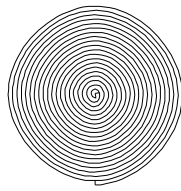

7/8" Mastic Tape (40' Roll)  
Part Code: BTR  
Used:  
-Between rake trim and roof panel  
-Top and bottom of closures at roof  
-Roof panel side lap  
-Roof panel end lap



Touch-Up Paint  
Part Code: 4\_SP

## BUILDING OVERVIEW

### Framing

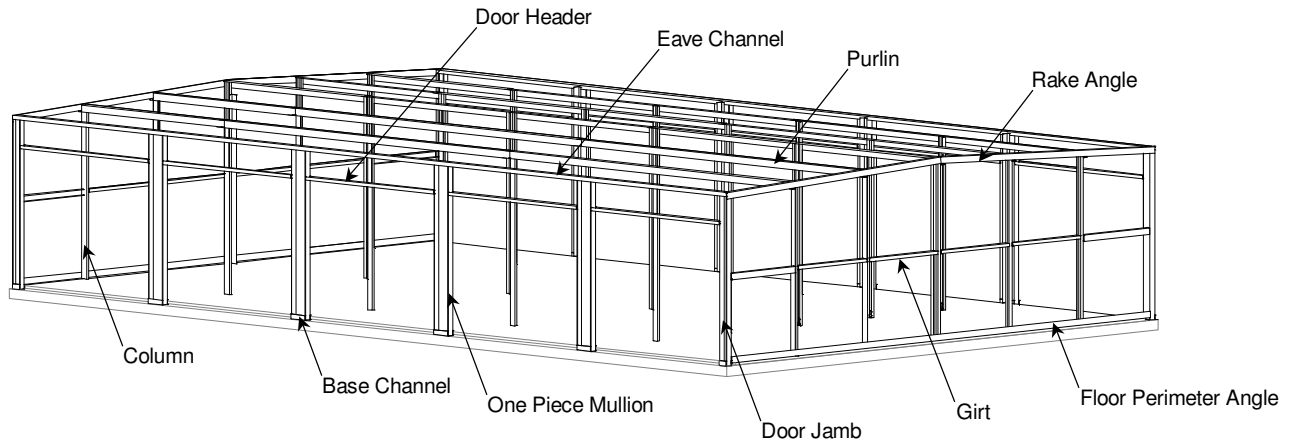

### Panels and Trim

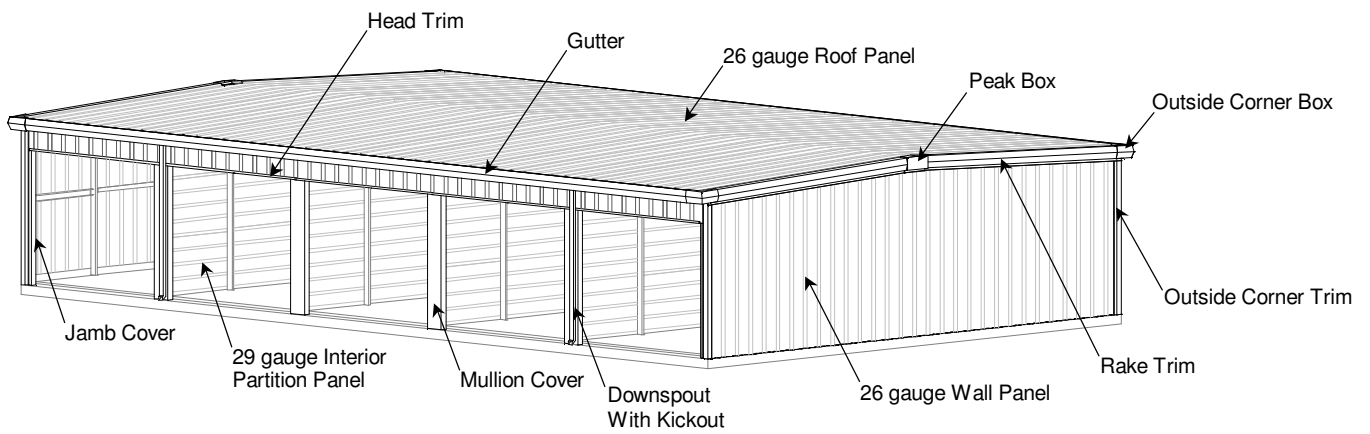

## FOUNDATION

- Tools Needed
  - Tape Measure
  - Hammer Drill
  - 3/4" Wrench or Socket
  - Chalk Line Reel
  - 1/2" Masonry Drill Bit
  - Hammer
- Material Needed
  - Base Clip, Channel, and Angles
  - 1/2" Wedge Anchor, Nut, and Washer
- Standard Foundation Layout
  - Building supplier is not responsible for foundation design or material selection.
  - Foundation will typically be 3" wider and longer than building steel dimension.
    - Refer to erection drawings for slab and notch dimensions.
  - Slab will have a 1 1/2" recess at each side, permitting wall panels to run past finished floor level.
    - Wall edge notch will be 1 1/2" x 1 1/2"
    - Door edge notch will be 9 1/2" x 1 1/2"

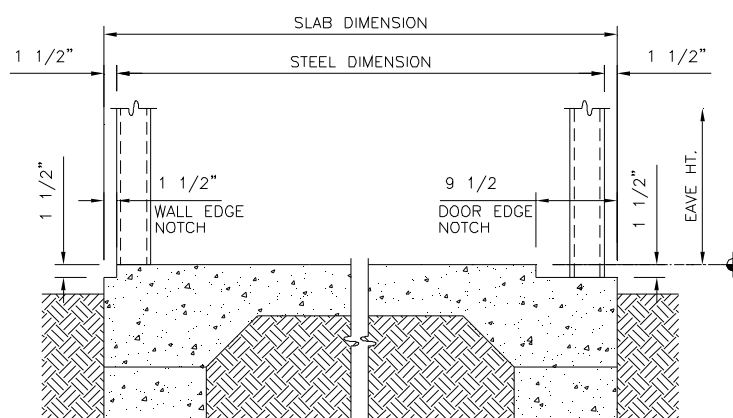

- Mark Column Locations With Chalk Line
  - Refer to erection drawings for column spacing. (5'-0" O.C. Typical)
- Stage Floor Clips, Base Channels, And Perimeter Angles
  - Refer to erection drawings for proper location.
- Fasten Floor Clips, Base Channels, And Perimeter Angles To Foundation
  - Place clips and channels squarely on chalk lines.
    - Interior Base Clip/Channel will sit to one side of Chalk Line
    - Vertical leg will typically face low eave of building, sitting on the ridge/high eave side of chalk line
    - Refer to erection drawings for column location and orientation
    - Base Channel is 1/4" shorter than mullion. Center Base Channel on centerline of bay.
    - Do not lap perimeter angle.
  - Using a 1/2" diameter bit, drill hole to 2" depth. Clean hole.
  - Tap in 1/2" x 2 3/4" wedge anchor with hammer.
  - Place washer over bolt and tighten nut with wrench or socket.

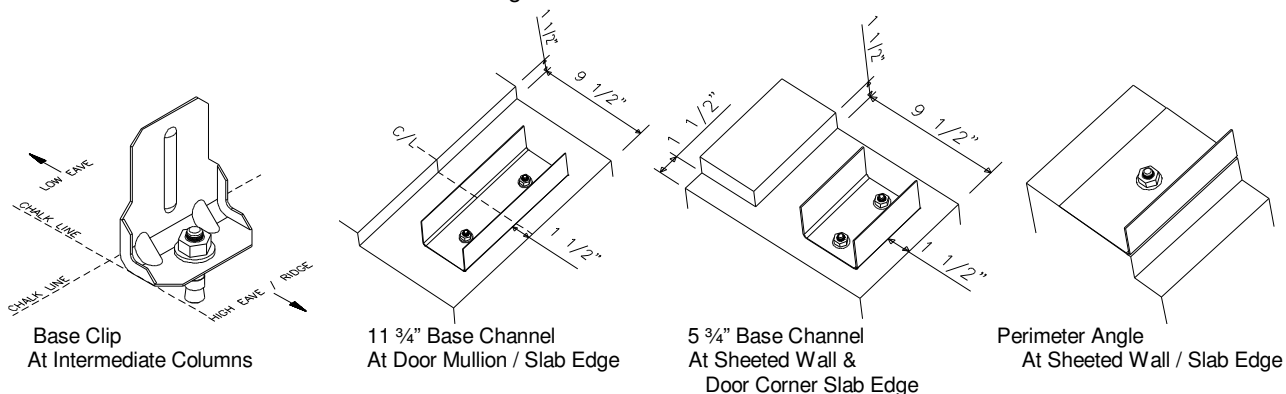

## FRAMING

- Tools Needed
  - Screw Gun
  - 5/16" Nut Driver
  - Level
  - Metal Nibbler
- Materials Needed
  - Framing Members
  - #12 x 1" Self Drilling Tek Fastener (No Washer)
- Stage Framing Material
  - Identify columns, girts, and purlins then stage in proper location.
    - Note: All framing members will be shipped pre-marked with a piecemark and length.
- Fasten Columns To Floor Clips (at intermediate columns)
  - Place column over clip and connect with two (2) #12 x 1" self-drilling fastener using a screw gun with a 5/16" nut driver.
    - 4" web will typically face low eave of building.
    - Refer to erection drawings for column location and orientation.

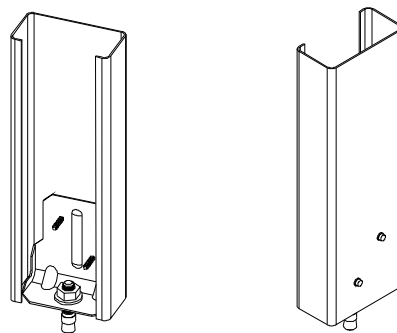

Base Clip / Column Assembly

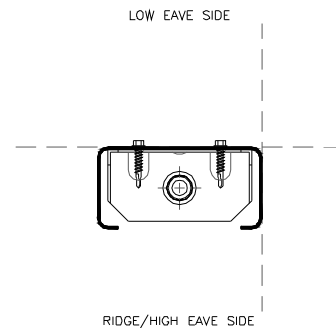

Section Through Column at Base Clip

- Connect Columns to Channels (at door jambs)
  - At Sidewall - Place one piece column inside channel and connect from behind with four (4) #12 x 1" self-drilling fasteners using a screw gun with a 5/16" nut driver.
  - At Endwall - Place column inside channel and connect with four (4) #12 x 1" self-drilling fasteners.
    - Note: Door jambs will be erected after purlins and rake angles are installed.

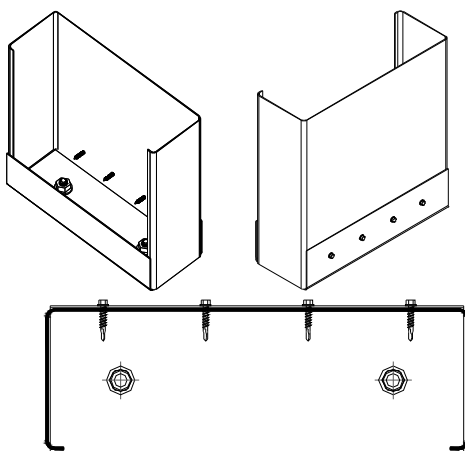

Sidewall Base Channel / One Piece Mullion Assembly

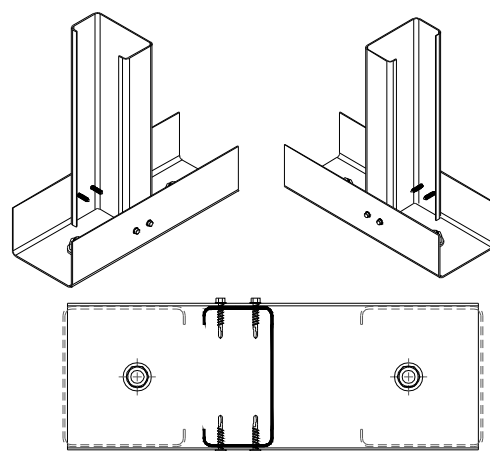

Endwall Base Channel / Column Assembly

## FRAMING

- Connect Columns To Perimeter Angle
  - Place column against angle and connect with two (2) #12 x 1" self-drilling fasteners using a screw gun with a 5/16" nut driver.

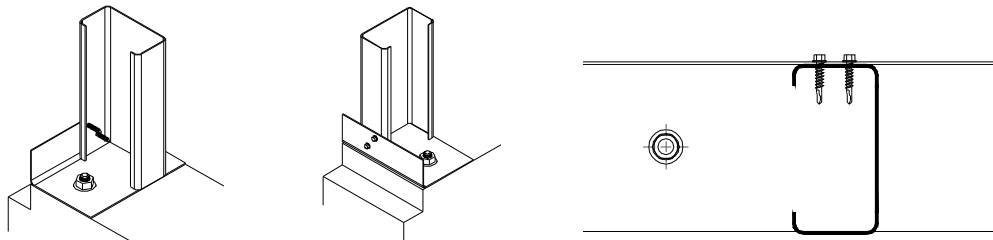

Perimeter Angle / Column Assembly

- Connect Partition Angle To Back Of Mullion
  - Connect partition angle to back of 12" mullion with #12 x 1" self-drilling fasteners at 12" O.C.
  - Partition Angle will typically be 1" shorter than column.

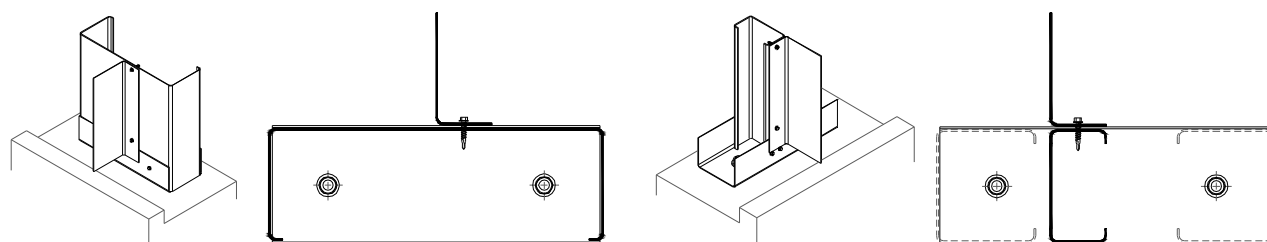

Partition Angle at One Piece Mullion (Sidewall)

Partition Angle at Three Piece Mullion (Endwall)

- Erect Bottom Partition Panel At Interior Walls
  - Attach bottom partition panel at partition angle and columns with #12 x 1" self-drilling fasteners.
  - Refer to erection drawings for fastener spacing.
  - Use level to make sure columns are plumb.

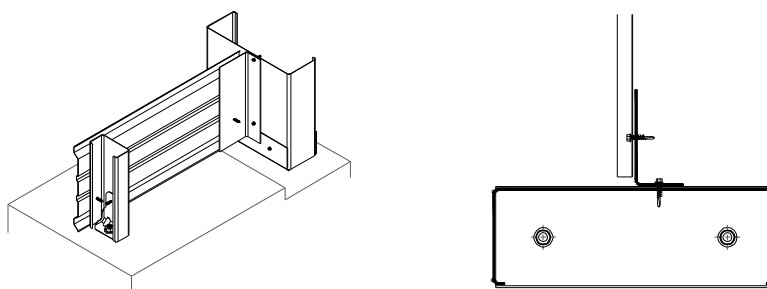

Partition Panel at One Piece Mullion

- Install Corner Column
  - Place door jamb and column in 5 3/4" channel and connect with #12 x 1" self drilling fasteners.

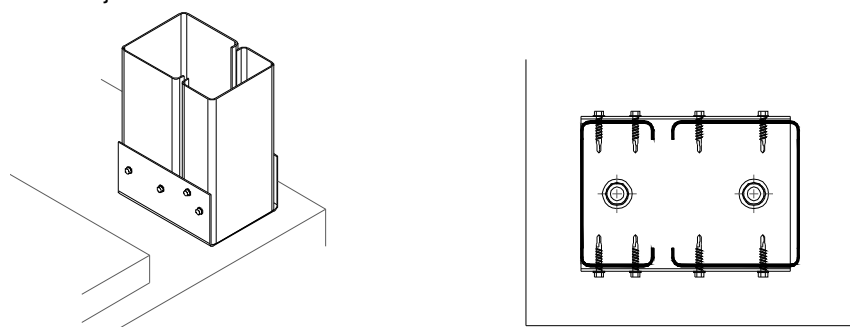

Door Jamb and Column at Corner

## FRAMING

### • Install Girts

- Attach Mini-clip to column at midpoint of column with two (2) #12 x 1" self-drilling fasteners.
- Place girt over mini-clip and secure from above with two (2) #12 x 1" self-drilling fasteners.
  - Note: Girt will typically be 1/2" shorter than column-to-column dimension.
  - Typically girt should sit on mini-clip as shown; however, mini-clip may be installed on top of girt to ease installation at back-to-back clip conditions.
  - Girts at 6" Door Jamb condition will be turned 90° to allow clearance for door track.

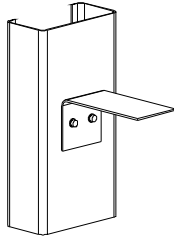

Mini-Clip at Sidewall Column

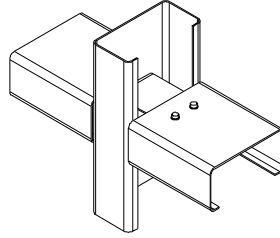

Girt at Sidewall Column

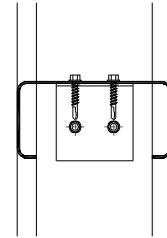

Section View at Sidewall Girt

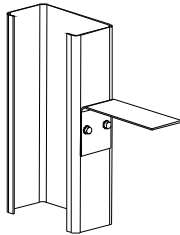

Mini-Clip at Endwall Column

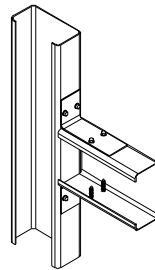

Girt at Endwall Column

Section View at Endwall Girt  
At 6" Door Jamb Condition

### • Install Purlins

- Position purlin over column and secure with #12 x 1" self-drilling fasteners.
  - Refer to erection drawings for fastener quantity
- Continue length of the building overlapping 8" minimum where purlins meet.
- Purlin must be lapped at a column location.
- Notching of lower leg may be required at endwall to clear door jamb at 3-piece mullion.
- Buildings without longitudinal partitions may require a knee brace angled between column and purlin.

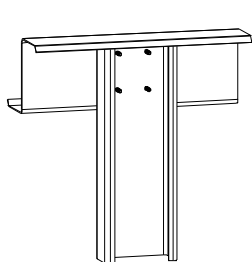

Purlin /Column Connection

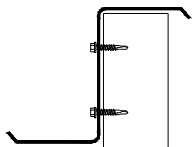

Purlin Section

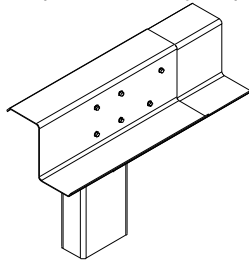

Purlin Lap

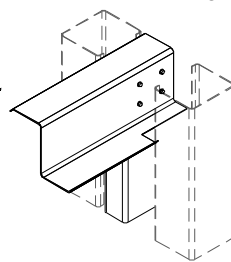

Purlin at Endwall Column

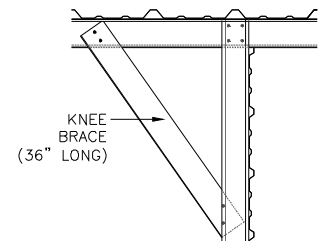

Angle Knee Brace

### • Install Eave Channel

- Place eave channel on top of mullions.
- Fasten to mullion/door jamb with #12 x 1" self-drilling fasteners.
  - Eave Channel will typically be 1/8" shorter than the bay it spans.
  - When eave channel splices at single column conditions, attach mini-clip to one side of column.
  - At 6" endwall door jambs, the eave channel must be notched to clear door jamb.

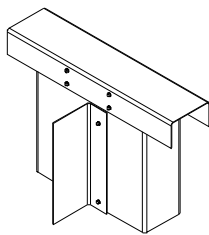
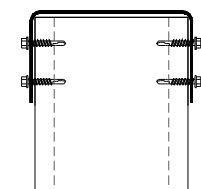
Eave Channel  
at 12" Mullion

Eave Channel Section

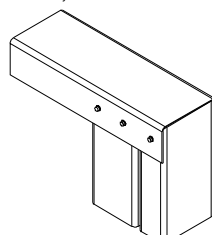
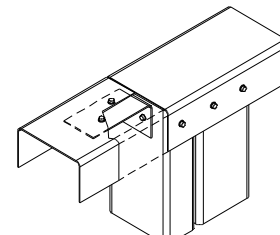
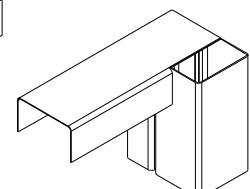
Eave Channel  
At Door jambEave Channel Splice  
w/ Mini-ClipEave Channel Notch  
at 6" Endwall Door Jamb

# FRAMING

- Install Rake Angle
  - Position rake angle on top of endwall column with long leg vertical.
  - Fasten to purlin and column with #12 x 1" self-drilling fasteners.
    - Note: If lapping is required, lap rake angle at a purlin location.

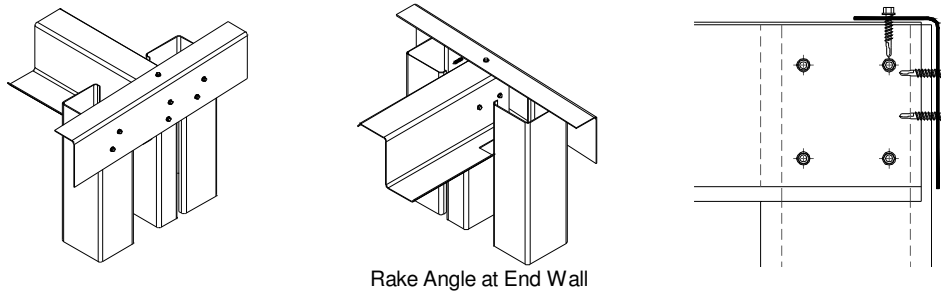

Rake Angle at End Wall

- Install End Wall Door Jambs
  - Place door jambs inside channel and connect with two (2) #12 x 1" self-drilling fasteners.
  - Connect door jambs to rake angle with two (2) #12 x 1" self-drilling fasteners.

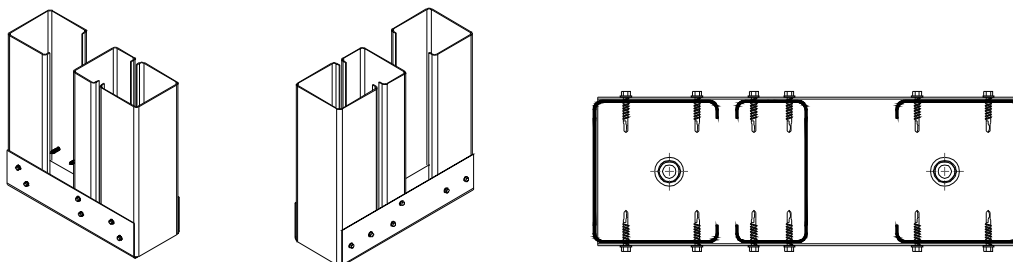

Endwall Base Channel / 3-Piece Mullion Assembly

- Install Door Headers
  - Identify headers and stage where required.
  - Pre-attach header cover and mini-clip to header with (2) #12 x 1 1/4" colored self-drilling fastener with washer. Fasten trim to door head at 24" O.C.
    - Door header will typically by 1/4" shorter then door opening width.

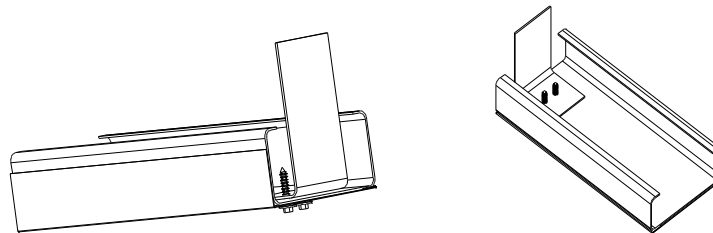

Door Header with Header Cover and Mini-Clip Attached

- Lift header assembly into place and attach to mullion/door jamb with (2) #12 x 1" self-drilling fasteners.
- 10' wide endwall units will require a header reinforcement and stub column to support purlin

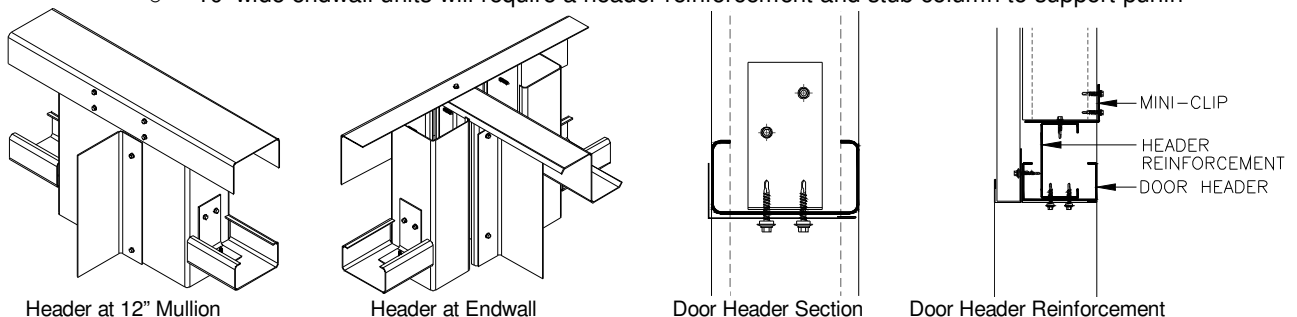

Header at 12" Mullion

Header at Endwall

Door Header Section

Door Header Reinforcement

## INTERIOR PARTITION PANELS

- Finish Out Transverse Partition Panels
  - Position partition panels so that panels overlap.
  - Secure to columns with #12 x 1" self-drilling fasteners.
  - Continue until paneling reaches purlins.
  - Trim top sheet to match roof pitch and clear purlin leg to close in unit.

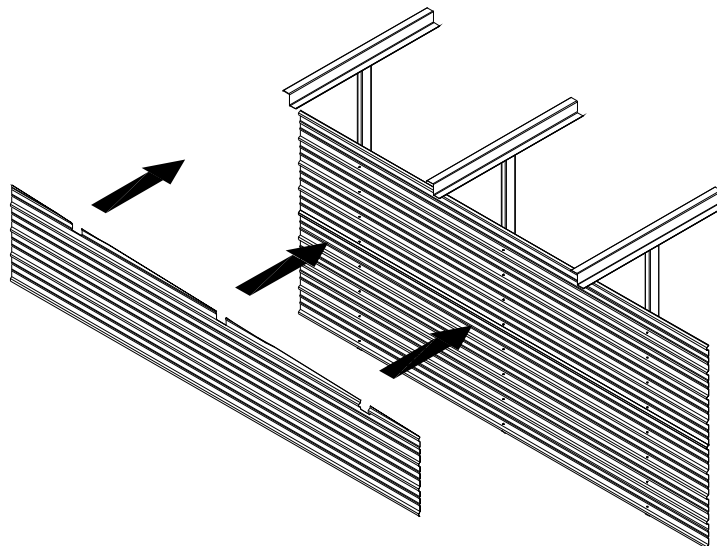

Partition Panel with Top Sheet Notched To Clear Purlins

- Erect Longitudinal Partition Panels
  - Attach partition angle to column at desired bay depth.
  - Secure to panel and column with #12 x 2" self-drilling fasteners @ 12" O.C.
  - Fasten partition panel to partition angle and column with #12 x 1" self-drilling fastener.
    - Refer to erection drawings for fastener spacing.

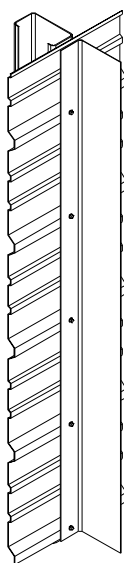

Partition Angle

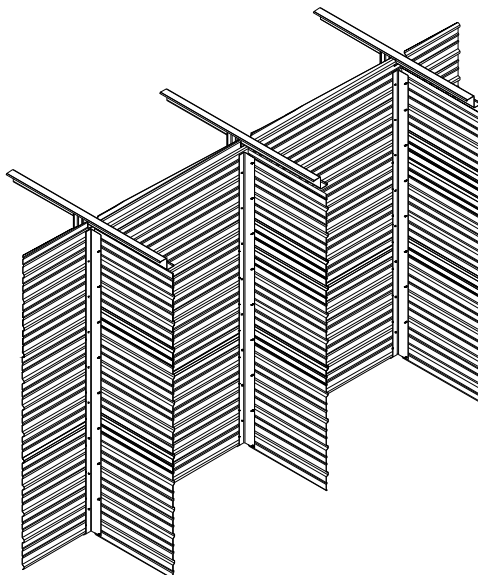

Transverse Panels/Partition Angle

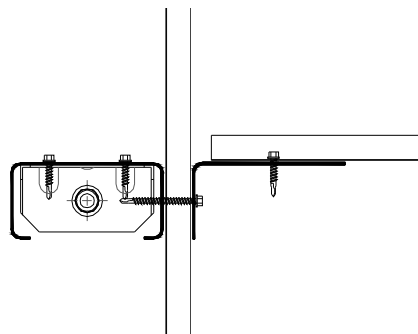

Section at Partition Angle

## EXTERIOR WALL PANELS AND TRIM

- Attach Mullion Cover
  - Place mullion cover over one-piece mullion and secure with #12 x 1 1/4" colored self-drilling fastener with washer at each end and 24" O.C.

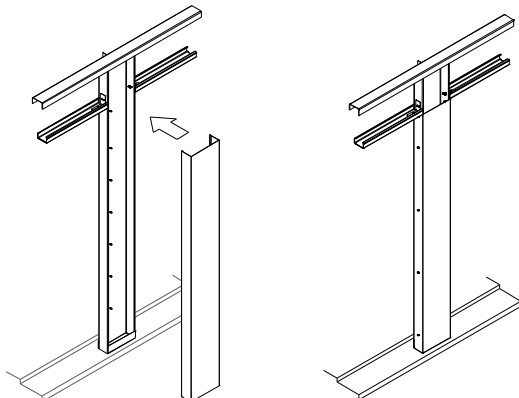

Mullion Cover At One Piece Mullion

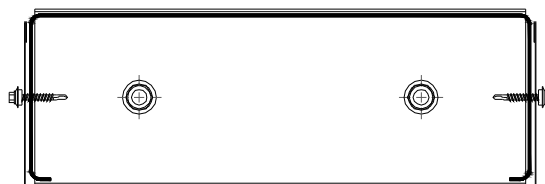

Section At Mullion Cover

- Install Jamb Cover And Jamb Trim (At Panel Wall Door Jamb)
  - Place jamb cover trim over door jamb
  - Fasten with #12 x 1 1/4" colored self-drilling fastener with washer at each end and 24" O.C.
  - Position Jamb Trim and fasten with #12 x 1 1/4" colored self-drilling fastener with washer @ 24" O.C.

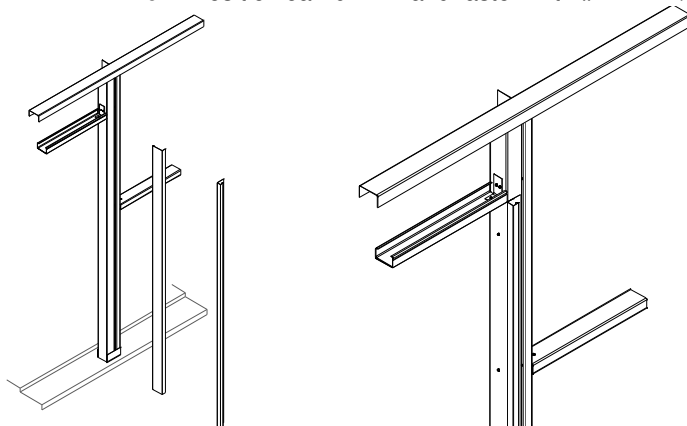

Jamb Cover &amp; Trim At 4" x 3 1/2" Door Jamb

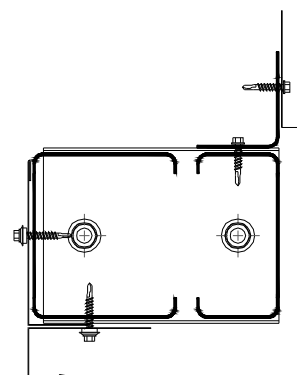

Section At Door Jamb

- Erect Wall Sheets
  - Position wall sheets so that sides lap at 36" O.C.
  - Double check that wall sheet is level.
  - Fasten wall sheet to base channel, wall girt, and eave channel (or rake angle) with #12 x 1 1/4" colored self-drilling fastener with washer. Refer to erection drawings for fastener spacing.
  - Direct contact with cement foundation, asphalt, gravel, or other corrosive materials is not recommended

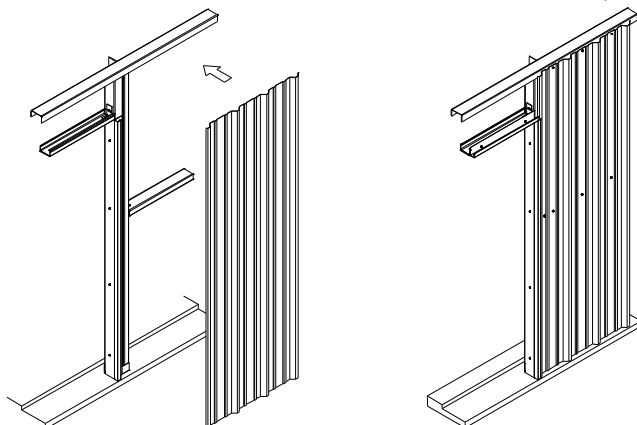

Wall Sheet At 4" x 3 1/2" Door Jamb

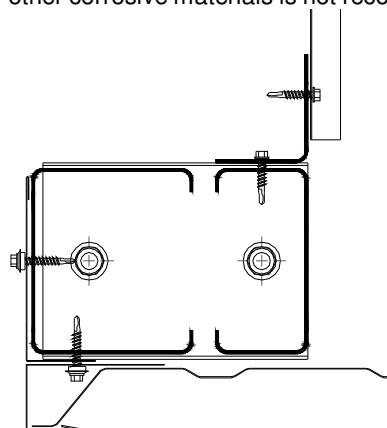

Section At Door Jamb

## EXTERIOR WALL PANELS AND TRIM

- Install Head Trim And Wall Panels Above Doors.
  - Attach head trim to header with (2) #12 x 1 1/4" self-drilling fastener with washer (one each end).
  - When possible, locate fastener to occur at high rib location of wall panel.
  - Place wall panel on top of head trim.
  - Fasten wall panel to header and eave channel (or rake angle) with #12 x 1 1/4" colored self-drilling fastener with washer. Refer to erection drawings for fastener spacing.
  - If needed, you may field drill weep holes in underside of head trim.

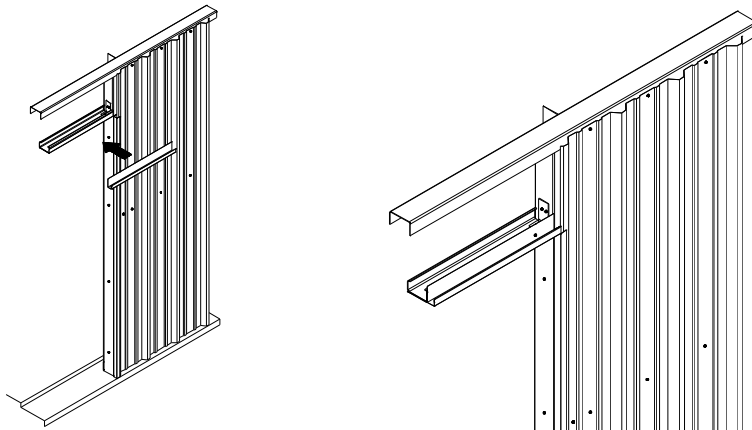

Attach Head Trim

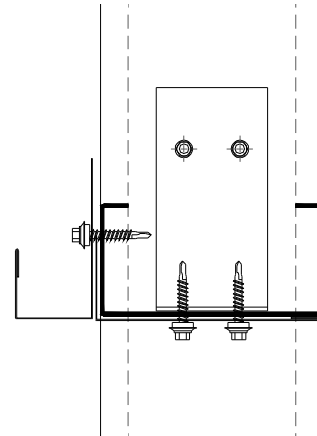

Section Through Head Trim

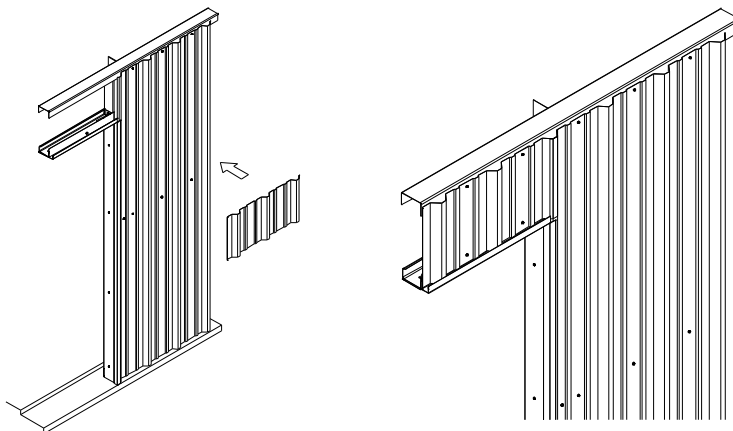

Wall Panel Above Door

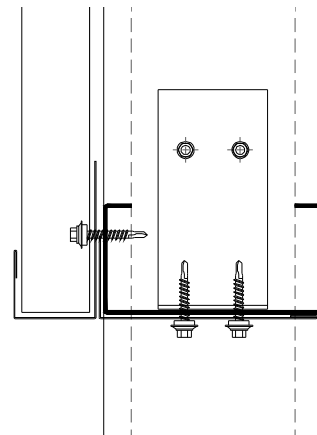

Section Through Wall Panel Above Door

- Install Corner Trim
  - Place Corner Trim over wall panels and fasten with #12 x 1 1/4" colored self-drilling fastener with washer @ 24" O.C.
  - Maintain gap between trim and concrete foundation. Direct contact may cause accelerated corrosion.

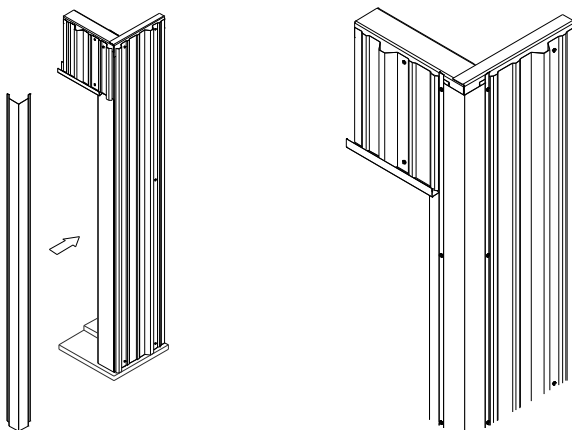

Outside Corner Trim

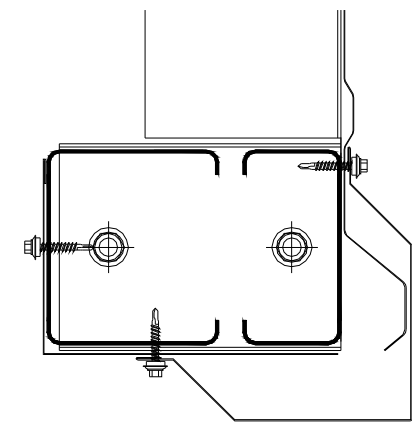

Section Through Outside Corner Trim

## ROOF PANELS AND TRIM

- Tools Needed
  - Screw Gun
  - 5/16" Nut Driver
  - 3/8" Nut Driver (Zac screws)
  - Metal Nibblers
  - Pop Rivet Gun
- Material Needed
  - Mastic
  - String Line
  - Geocel Sealant
  - Inside Closures
- Install Low Side Eave Trim
  - Use 3x3 Eave trim for building with gutters.
  - Use Long Eave Trim for building without gutters.
  - Position Eave Trim on top of Eave Channel.
  - Fasten to eave channel with (2) #12 x 1 1/4" self-drilling fastener with washer (one each end).

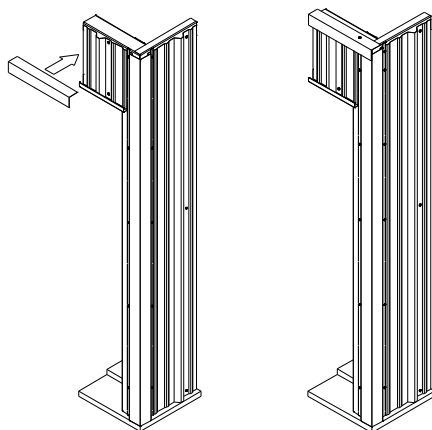

Low Eave Trim

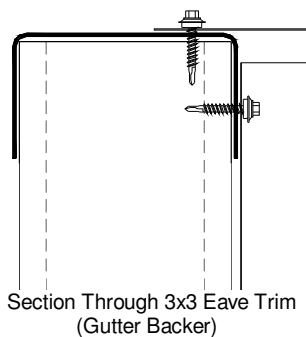

Section Through 3x3 Eave Trim  
(Gutter Backer)

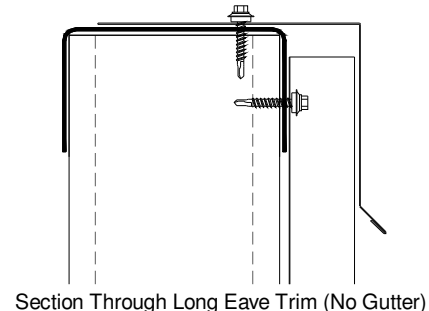

Section Through Long Eave Trim (No Gutter)

- Install Insulation (Optional)
  - Refer to insulation manufacturers recommended installation instructions.
  - Please note that insulation and other building materials that can soak up moisture should not be exposed to the exterior of the building. Install the insulation at least one inch above the bottom edge of the panels and fold the insulation face around the bottom edge of the fiberglass.

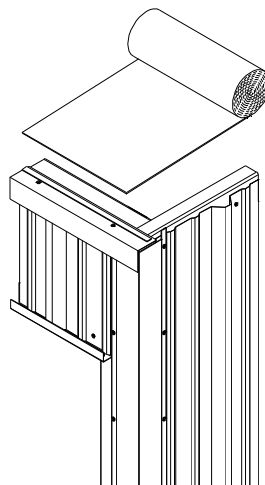

## ROOF PANELS AND TRIM

- Install Roof Panels
  - Place mastic at closure line, full length of building, leaving top paper backer in place
  - Place mastic tape on sidelap panel ridge, leaving paper backer in place.
  - Position first roof panel and make sure that the overhang is equal on both sides of the building.
  - Create a string line to measure roof panel placement.
  - Peel off paper backer and secure panel to neighboring panel.
  - Position inside closure at edge of eave channel so that it is aligned with underside corrugation of panel.
  - Peel back mastic paper on bottom of closure strip and mastic and secure to eave strut.
  - Place mastic on top of closure, leaving top paper backer in place.
  - Lift up roof panel, peel back mastic paper on top of closure.
  - Place roof panel over closure and fasten to eave channel and purlins with #12 x 1 1/4" colored self-drilling Zac with washer. See erection drawings for fastener spacing.
  - Fasten at sidelaps with #14 x 7/8" colored self-drilling Zac with washer at 24" O.C. max.
- Ridge Conditions
  - $\leq 1/2:12$  roof pitch –
    - Roof panel will typically run full depth of building.
    - Roof panel will rollover center purlin.
    - Buildings wider than 45' may require three (3) roof sheets (refer to erection drawings).
    - At 3 piece roof condition, run butyl tape continuous between roof panel end laps.
  - $> 1/2:12$  roof pitch –
    - A pitched roof will require (2) roof sheets and a formed ridge cap (refer to erection drawings).

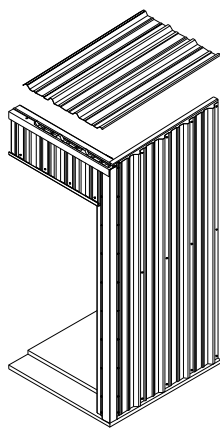

Roof Panels

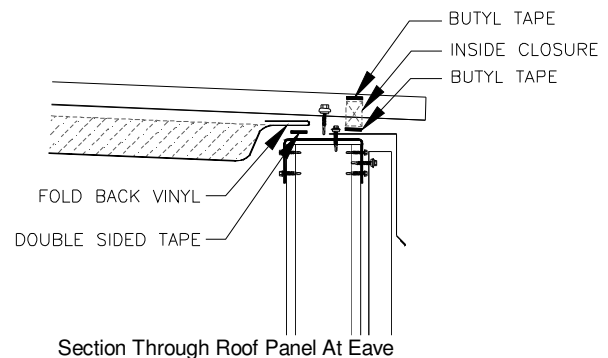
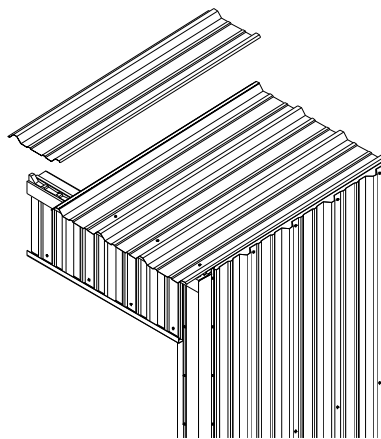

Section Through Roof Panel At Eave

- Install Gutters
  - Fasten gutter straps to panel high rib at 36" O.C. with #12 x 7/8" self-drilling Zac with washer.
  - Fasten gutter to roof panel and gutter straps with #12 x 7/8" self-drilling Zac with washer.
    - Fasten gutter to roof panel @ 12" O.C.
  - Seal gutter laps with geocel sealant and fasten with pop rivet as required.
  - Seal gutter end cap with geocel sealant and fasten with pop rivets as required.

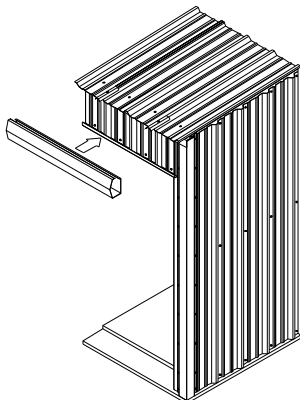

Gutter

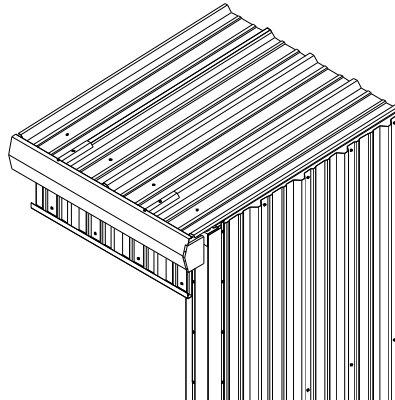

Gutter With End Cap

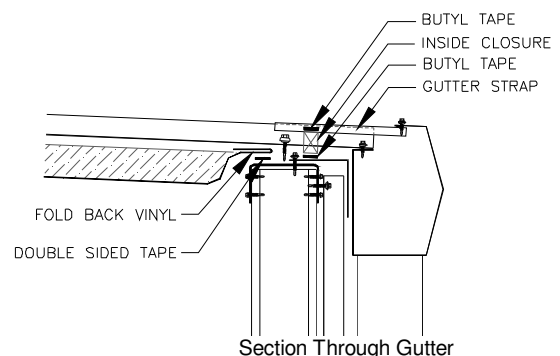

Section Through Gutter

## ROOF PANELS AND TRIM

- Install Rake Trim
  - Place mastic tape on top of corresponding roof panel.
  - Attach rake trim to roof panel with #14 x 7/8" self-drilling Zac with washer at 12" O.C.
  - Insert outside closure between rake trim and wall panel and fasten rake trim to panel high rib with #14 x 7/8" colored self-drilling fastener with washer at 12" O.C.

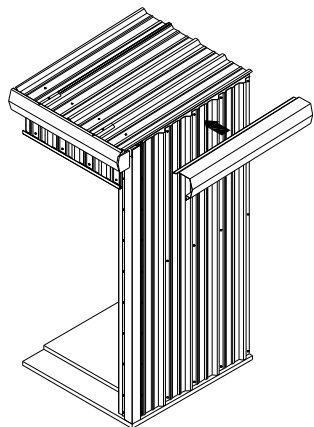

Rake Trim

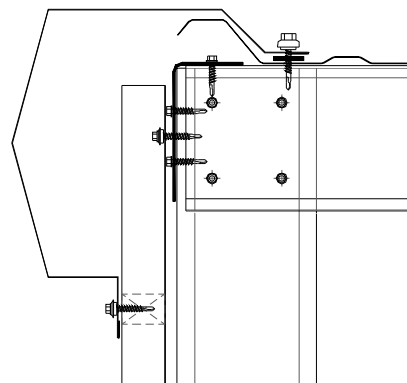
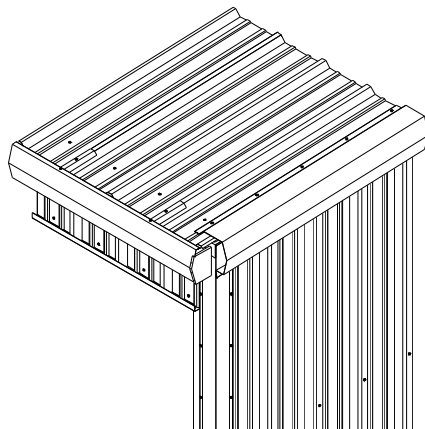

Section Through Rake Trim

- Install Rake End Cap (At buildings without gutters)
  - Fasten Rake end cap with pop rivets as required.

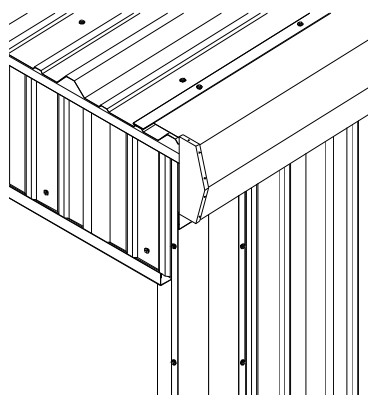

Rake Trim With End Cap

- Install Outside Corner Box (At buildings with gutter)
  - Seal connections with acrylic sealant and fasten with pop rivets as needed.

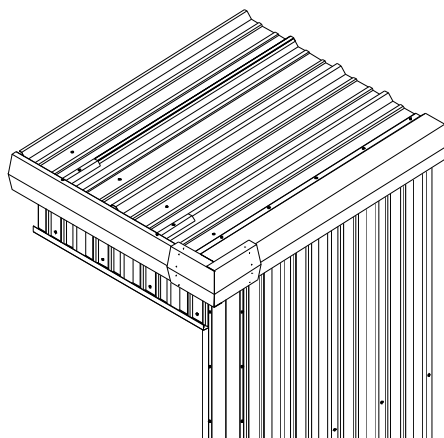

Outside Corner Box

## ROOF PANELS AND TRIM

- Install Downspouts
  - Attach downspout strap to mullion / wall panel with pop rivet or lap screw.
  - Field cut and bend downspout outlet in bottom of gutter.
  - Outside dimension of outlet will be  $3 \frac{3}{8}$ " x  $3 \frac{7}{8}$ ".
  - Insert downspouts from underneath.
  - Note: At steeper pitches, top of downspout may be mitered to match roof pitch to achieve a better fit.
  - Seal connection with Geocel sealant and fasten with pop rivets.
  - Secure base of downspout to strap with pop rivet.

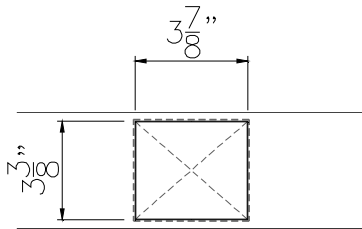

Gutter Fabrication At Downspout

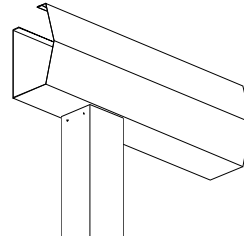
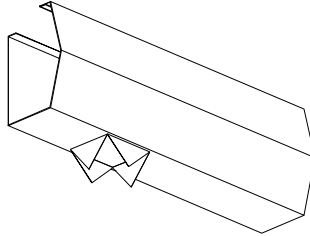

Downspout Attached To Gutter

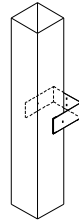

Downspout Strap

- Install Peak Box
  - Place peak box at top of ridge where rake trims meet.
  - Attach with #14 x 7/8" colored self-drilling Zac with washer.
  - Seal lap between peak box and rake trim with Geocel sealant.

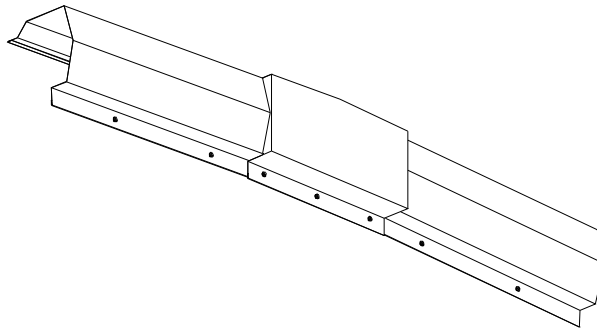

Peak Box

- 5. Assemble and Install Roll Up Doors
  - Refer to door manufacturers recommended installation instructions.

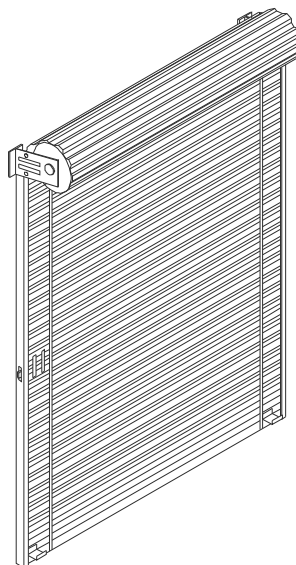

**MISCELLANEOUS DETAILS**

Sample Details Only – Refer to Erection Drawings For Job Specific Details

**BASE CONDITIONS**

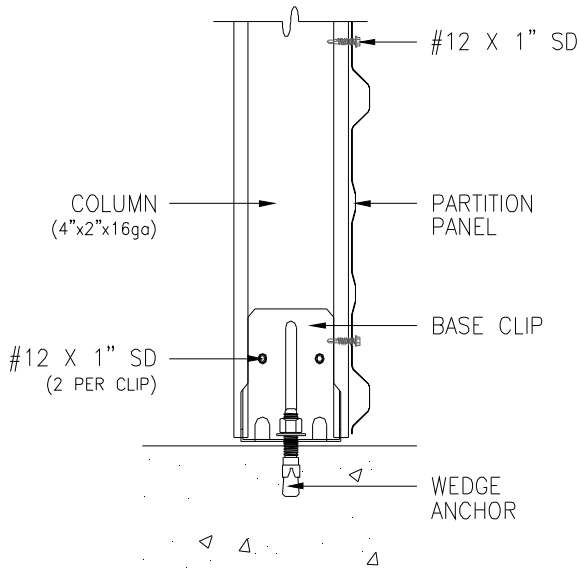

FLOOR BASE CLIP

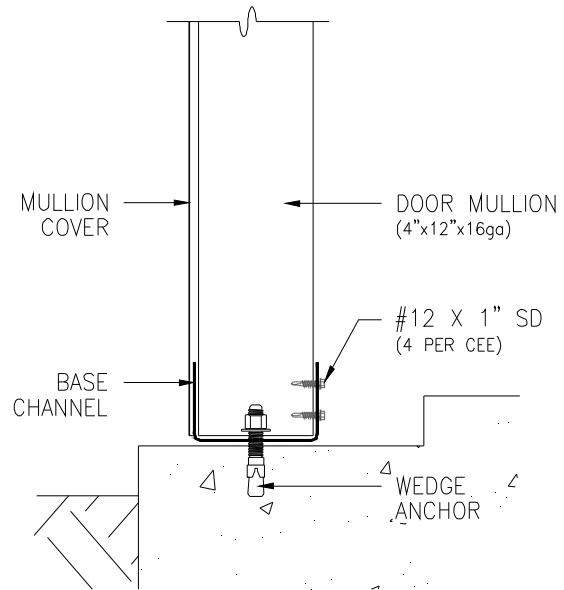

DOOR EDGE BASE CHANNEL

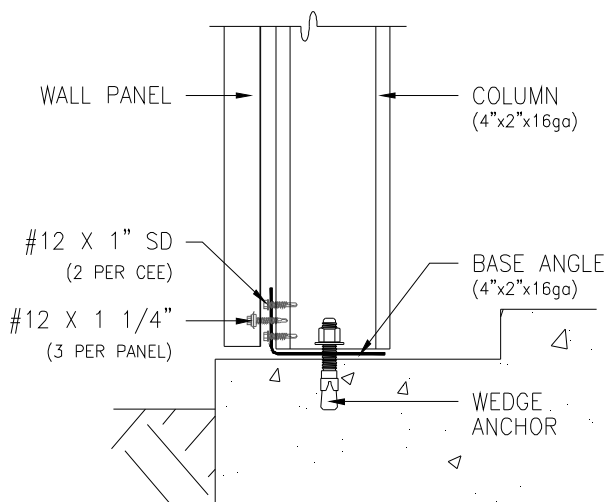

BASE ANGLE AT SHEETED WALL  
9 1/2" X 1 1/2" DOOR NOTCH

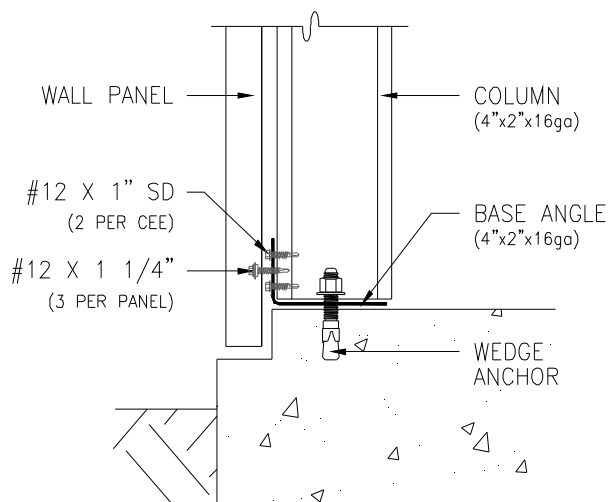

BASE ANGLE AT SHEETED WALL  
1 1/2" X 1 1/2" SHEET NOTCH

Erector note: Maintain gap between edge of galvalume material and concrete foundation.  
Direct contact with concrete, asphalt, gravel, dirt, mulch, etc. may cause accelerated corrosion.

**MISCELLANEOUS DETAILS**

Sample Details Only – Refer to Erection Drawings For Job Specific Details

**DOOR MULLION CONDITIONS**

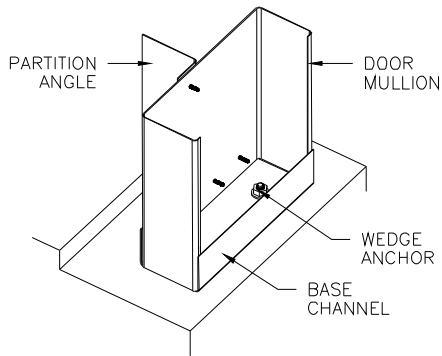

FRAMING ISOMETRIC VIEW

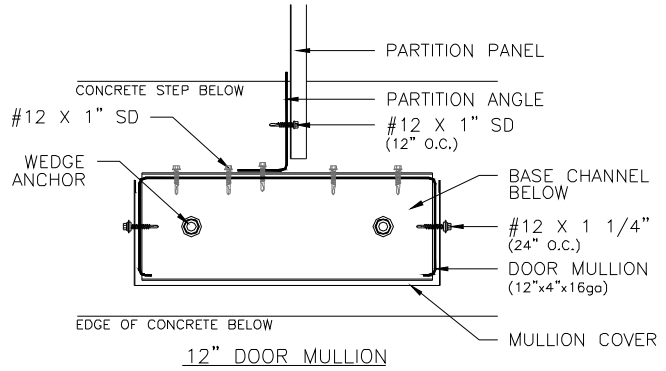

12" DOOR MULLION

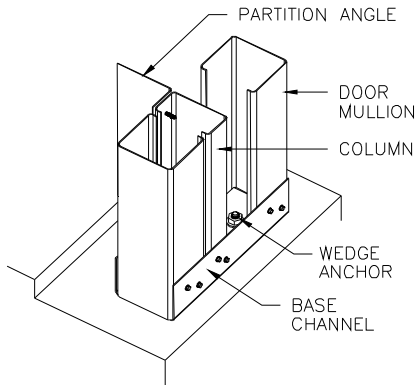

FRAMING ISOMETRIC VIEW

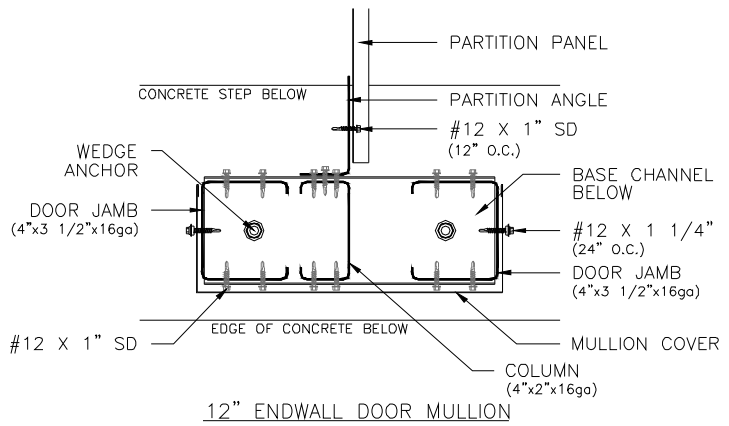

12" ENDWALL DOOR MULLION

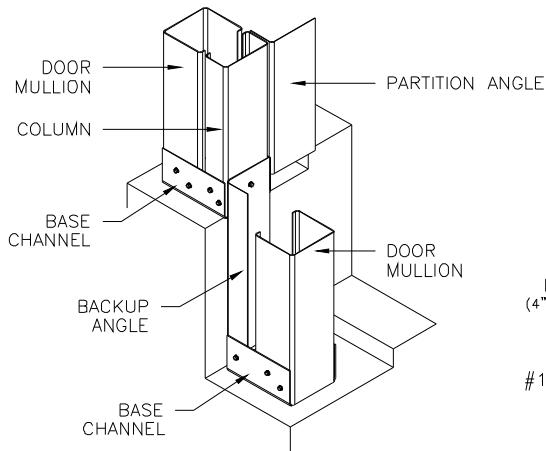

FRAMING ISOMETRIC VIEW

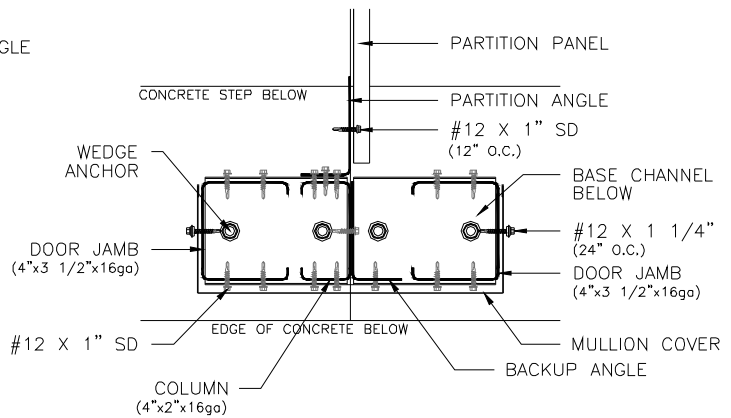

12" DOOR MULLION AT STEP

**MISCELLANEOUS DETAILS**

Sample Details Only – Refer to Erection Drawings For Job Specific Details

**6" DOOR JAMB CORNER**

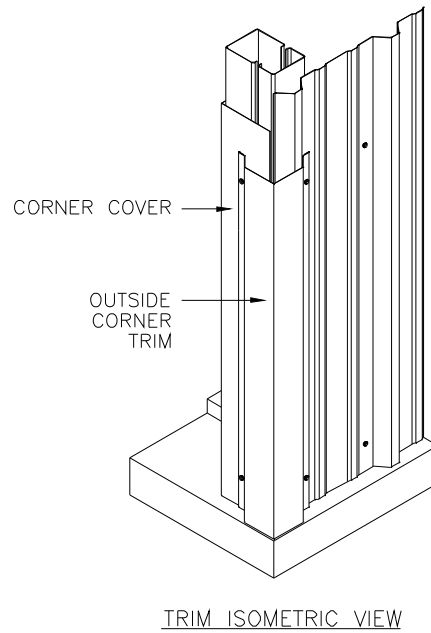
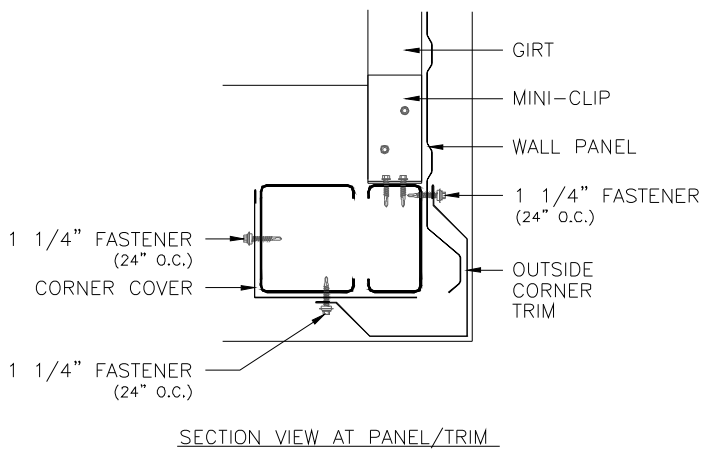
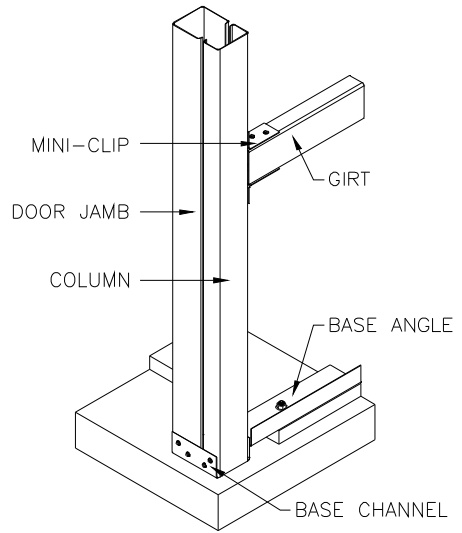
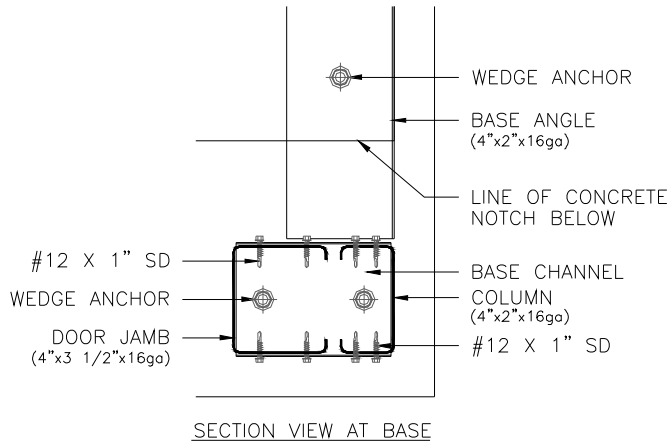

**MISCELLANEOUS DETAILS**

Sample Details Only – Refer to Erection Drawings For Job Specific Details

**DOOR HEAD / JAMB CONDITIONS**

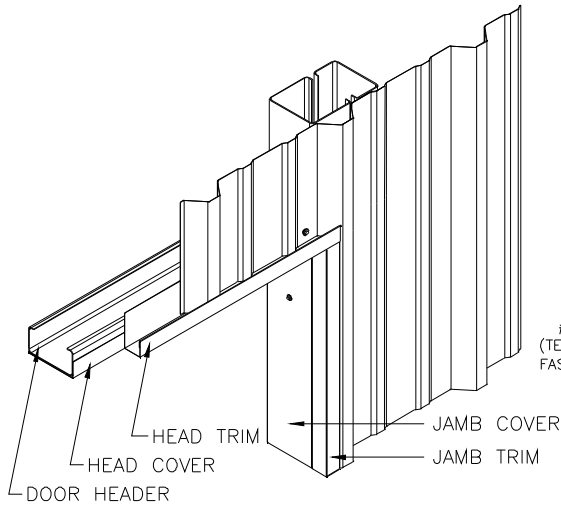

ISOMETRIC VIEW

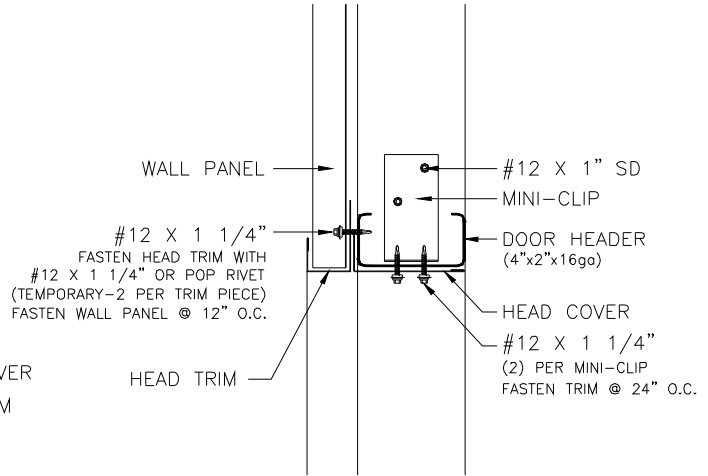

DOOR HEAD

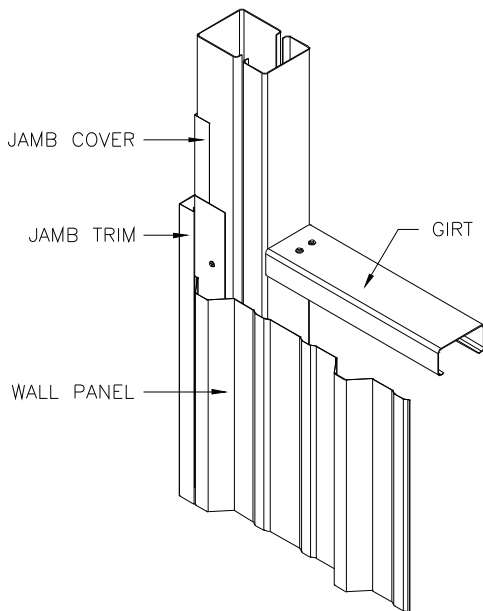

ISOMETRIC VIEW

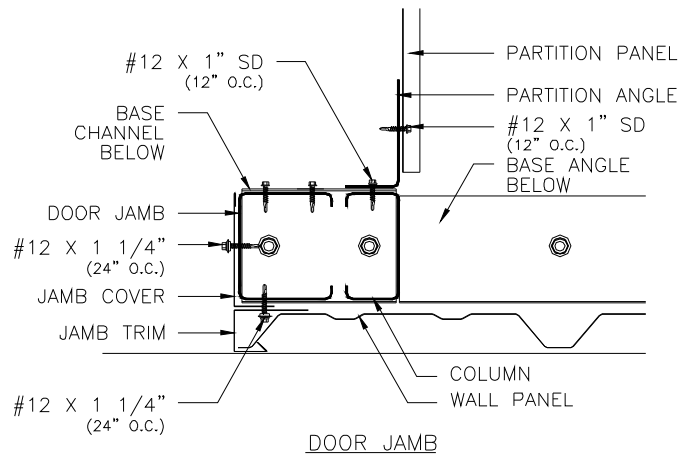

DOOR JAMB

**MISCELLANEOUS DETAILS**

Sample Details Only – Refer to Erection Drawings For Job Specific Details

**LONG EAVE TRIM**

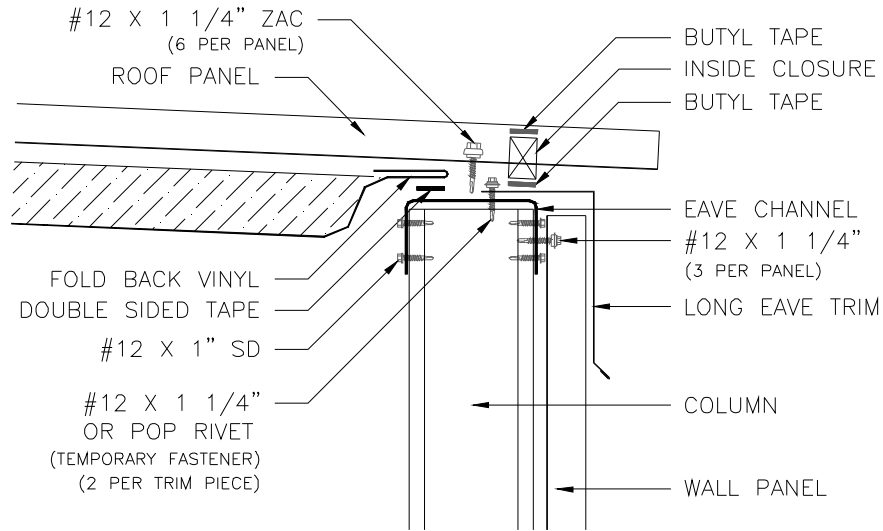

SECTION VIEW

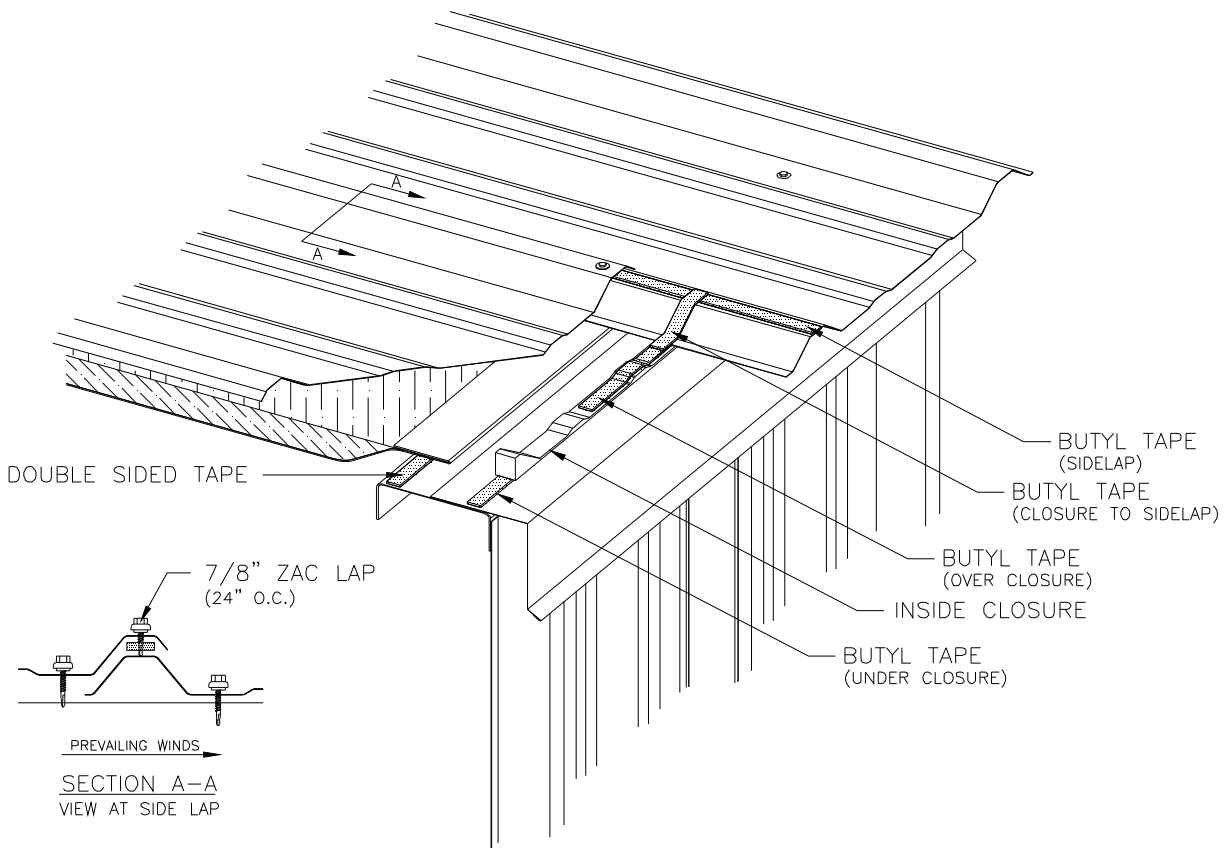

ISOMETRIC VIEW

**MISCELLANEOUS DETAILS**

Sample Details Only – Refer to Erection Drawings For Job Specific Details

**GUTTER**

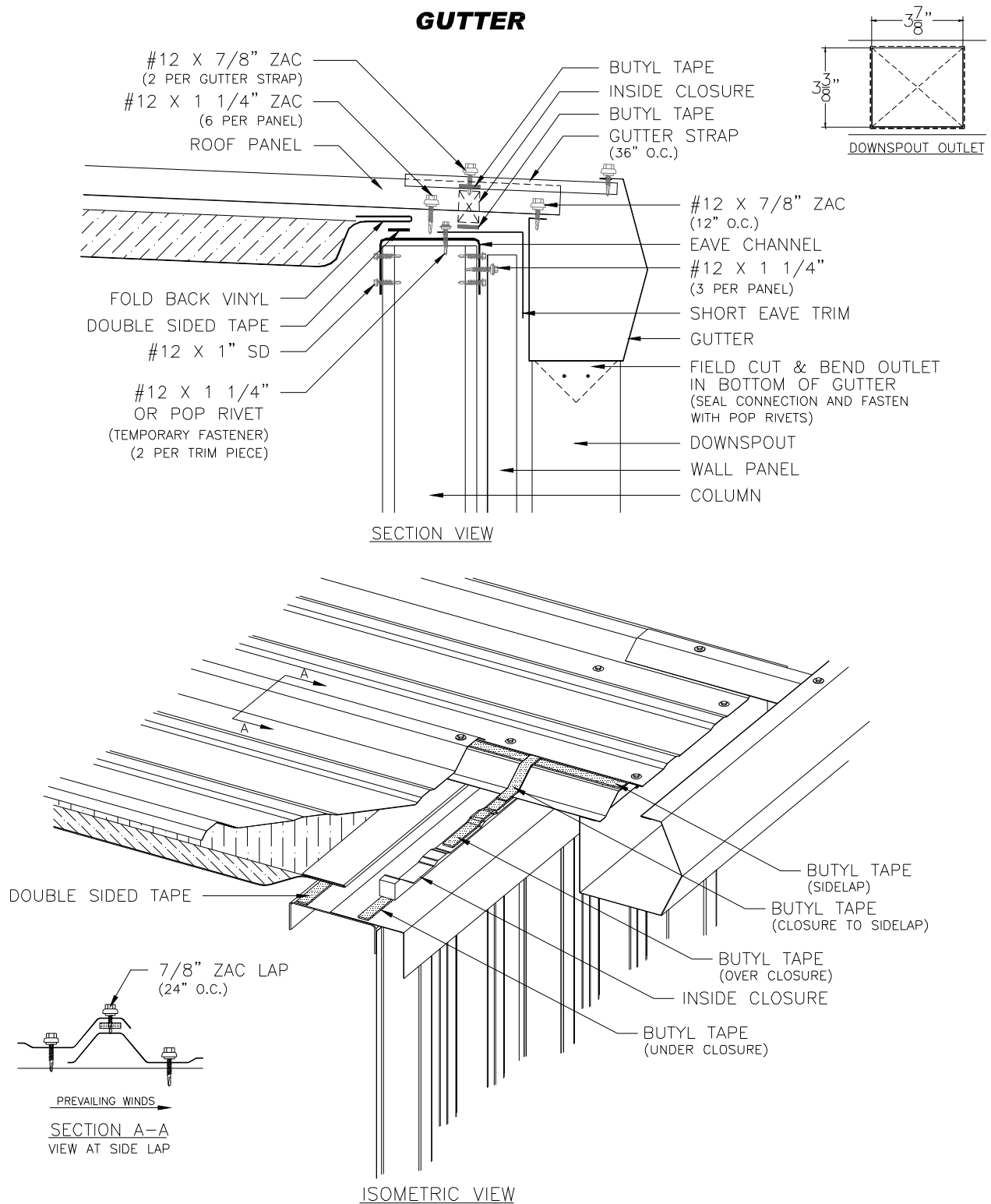

**MISCELLANEOUS DETAILS**

Sample Details Only – Refer to Erection Drawings For Job Specific Details

**GUTTER AT PITCHED ROOF**

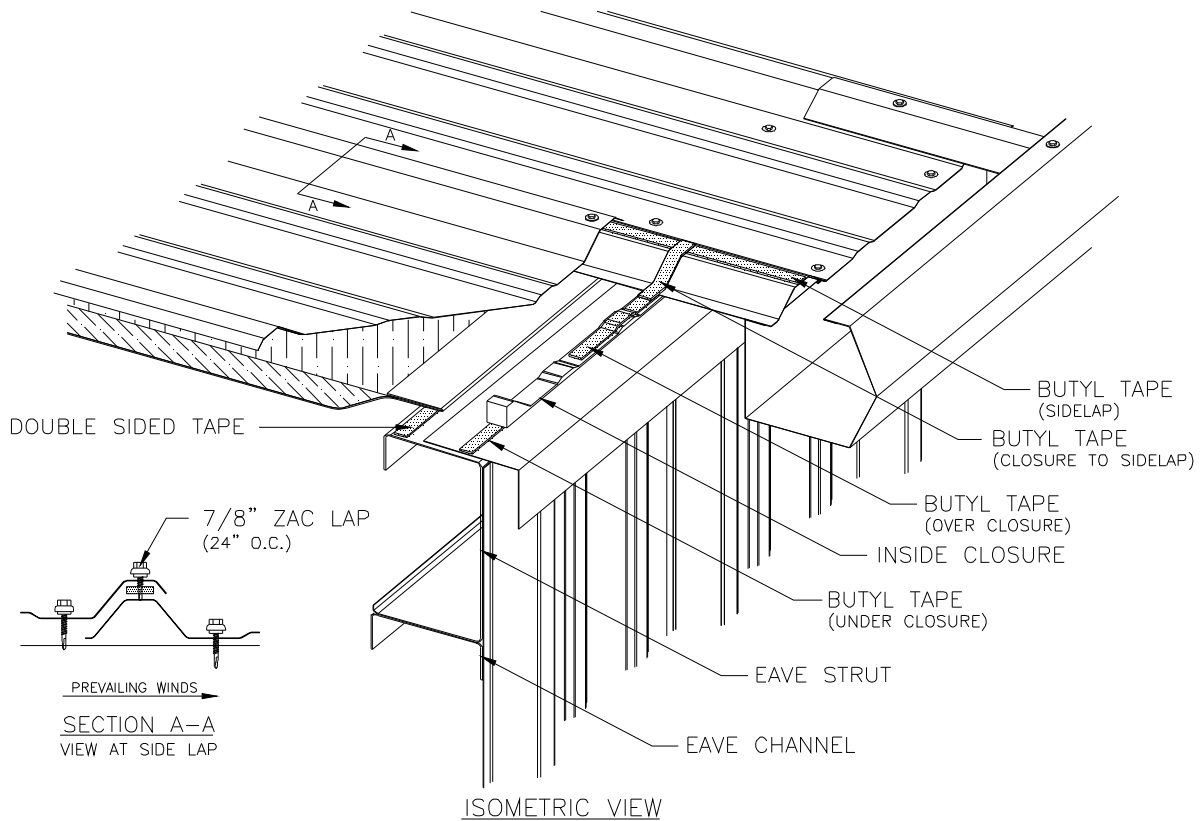
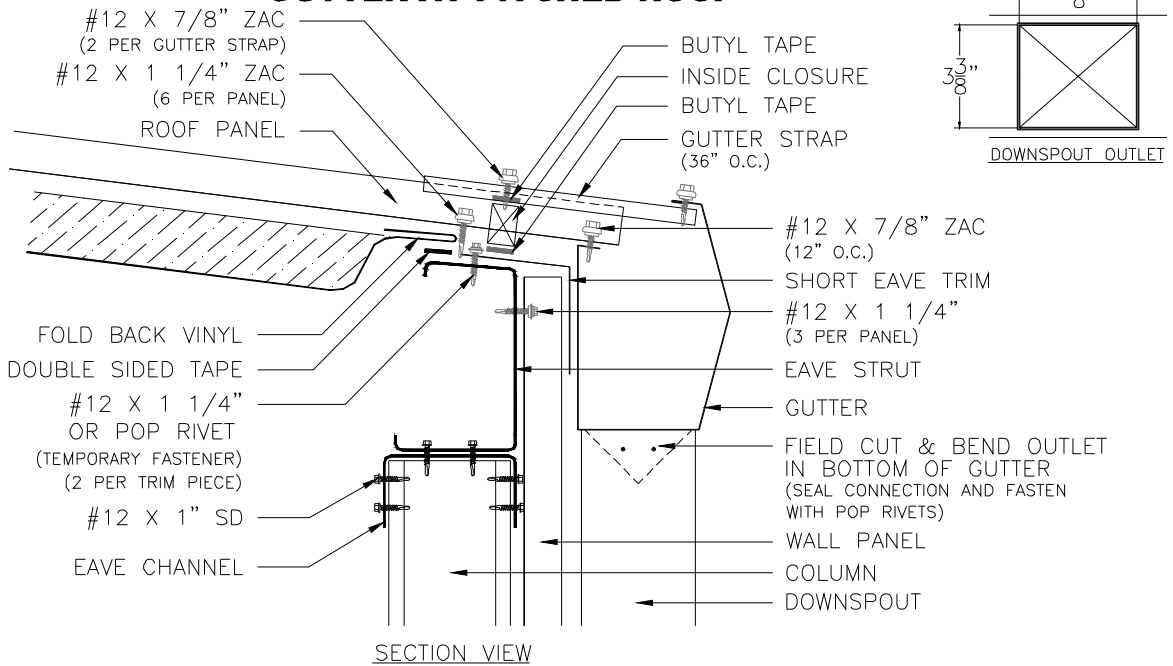

**MISCELLANEOUS DETAILS**

Sample Details Only – Refer to Erection Drawings For Job Specific Details

**OUTSIDE CORNER BOX**

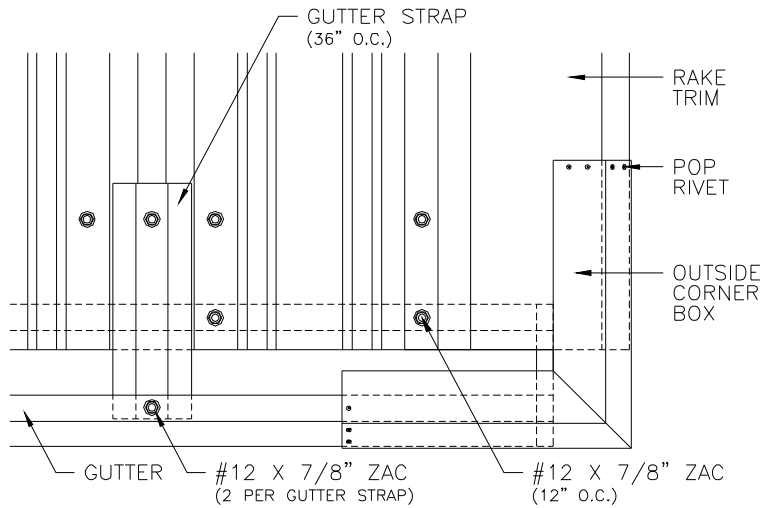

TOP VIEW AT OUTSIDE CORNER BOX

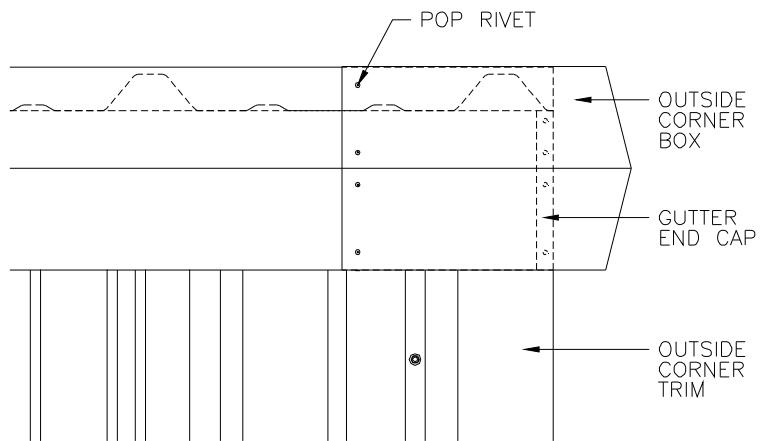

FACE VIEW AT OUTSIDE CORNER BOX

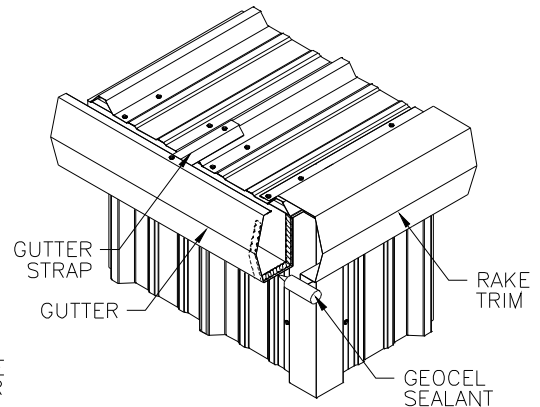

ISOMETRIC VIEW

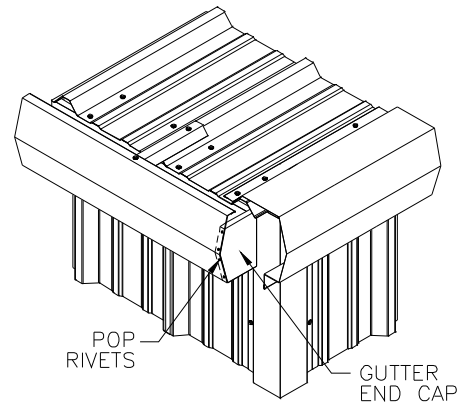

ISOMETRIC VIEW

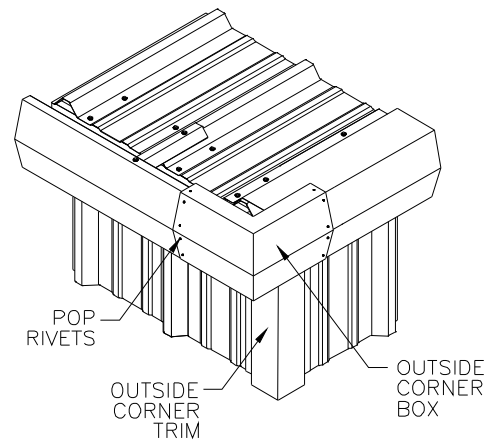

ISOMETRIC VIEW

**MISCELLANEOUS DETAILS**

Sample Details Only – Refer to Erection Drawings For Job Specific Details

**HIGH SIDE EAVE**

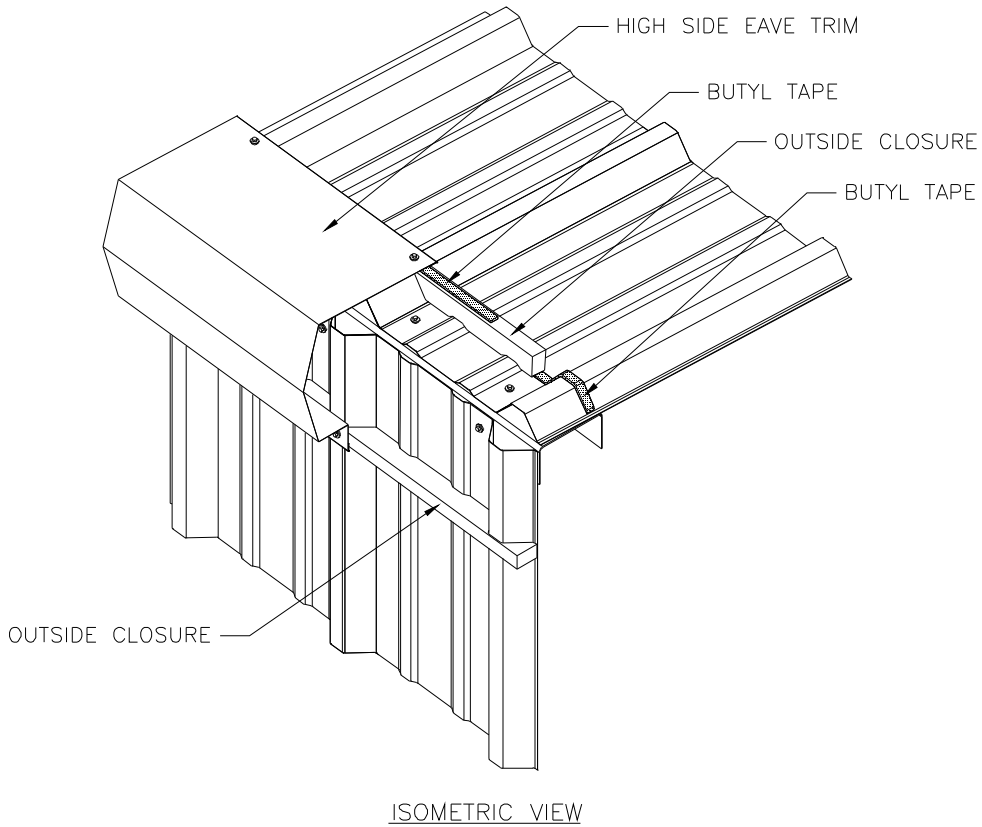
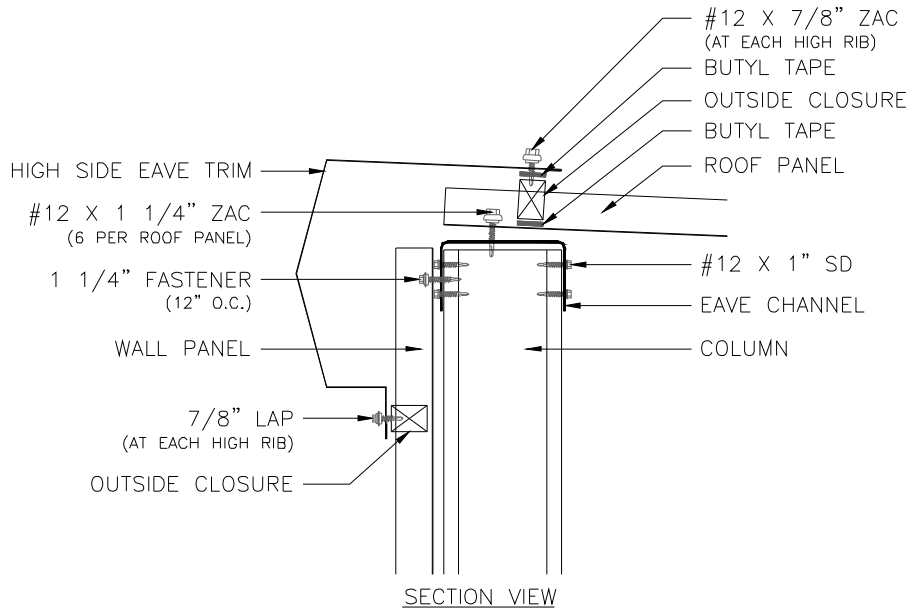

# MISCELLANEOUS DETAILS

Sample Details Only – Refer to Erection Drawings For Job Specific Details

## FORMED RIDGE CAP

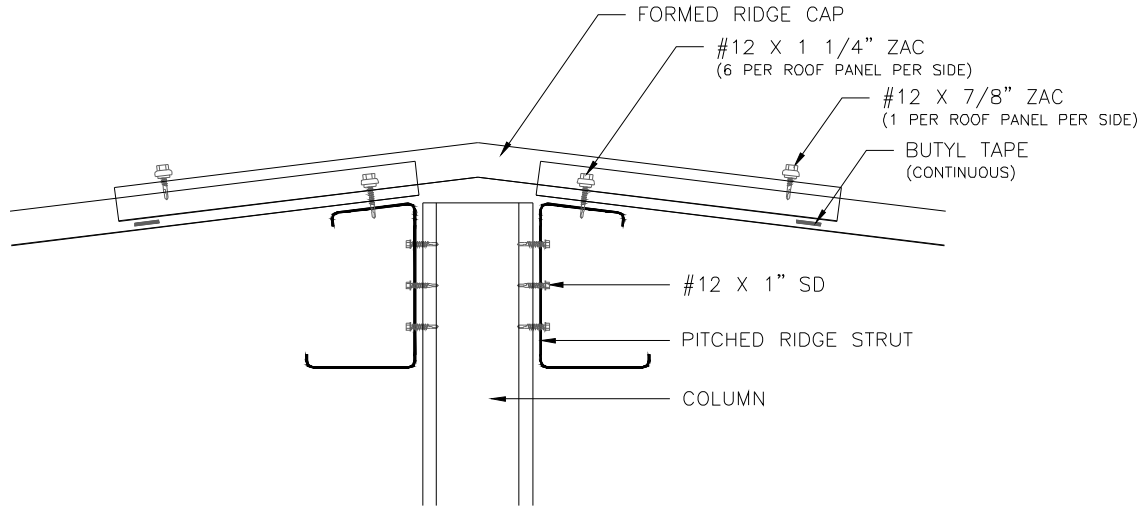

SECTION VIEW

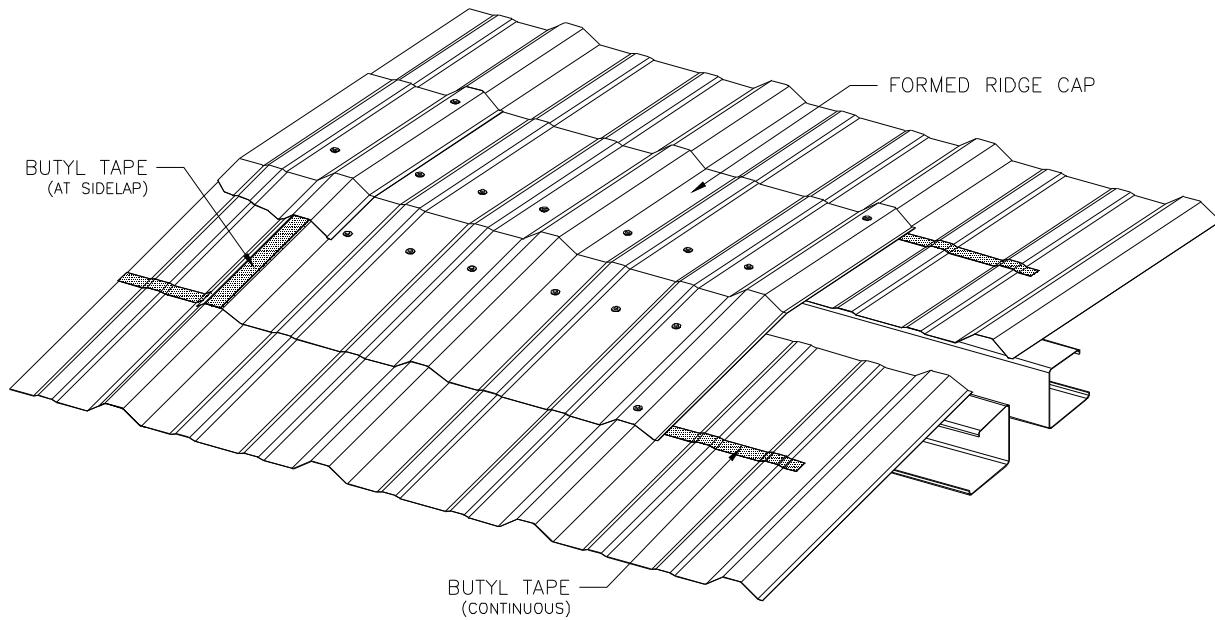

ISOMETRIC VIEW

**MISCELLANEOUS DETAILS**

Sample Details Only – Refer to Erection Drawings For Job Specific Details

**ROOF PANEL LAP ATTACHMENT**

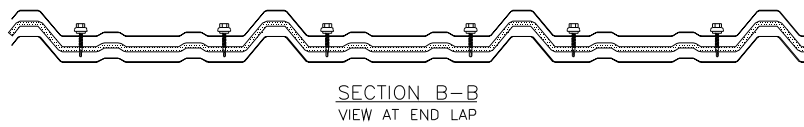
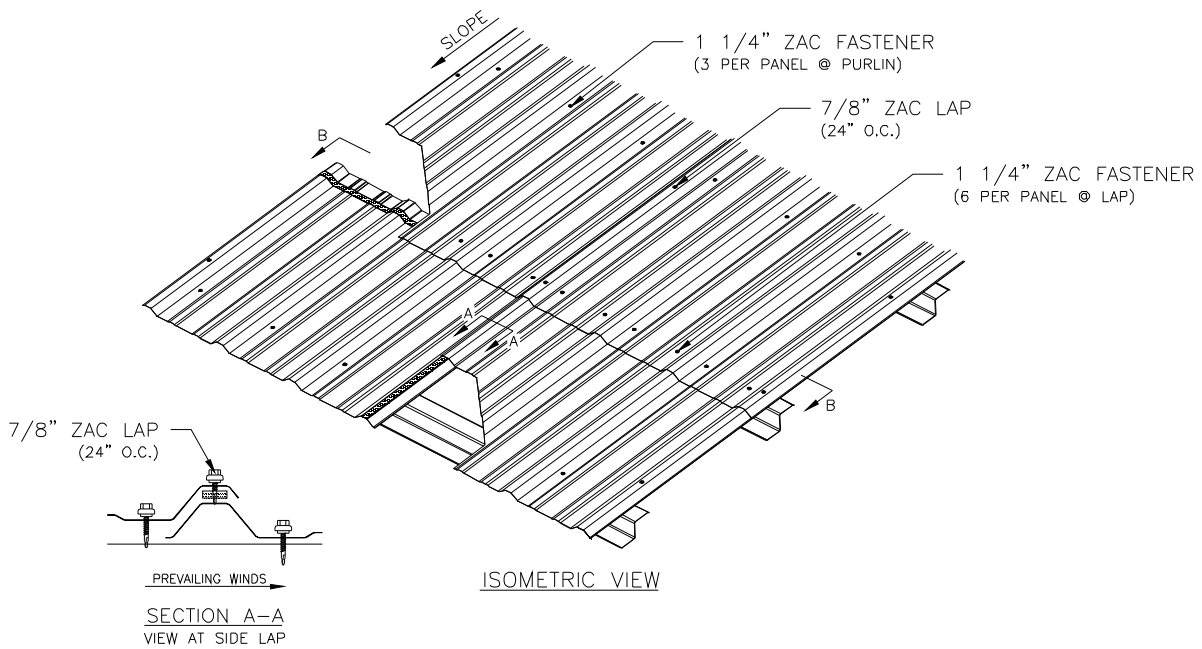
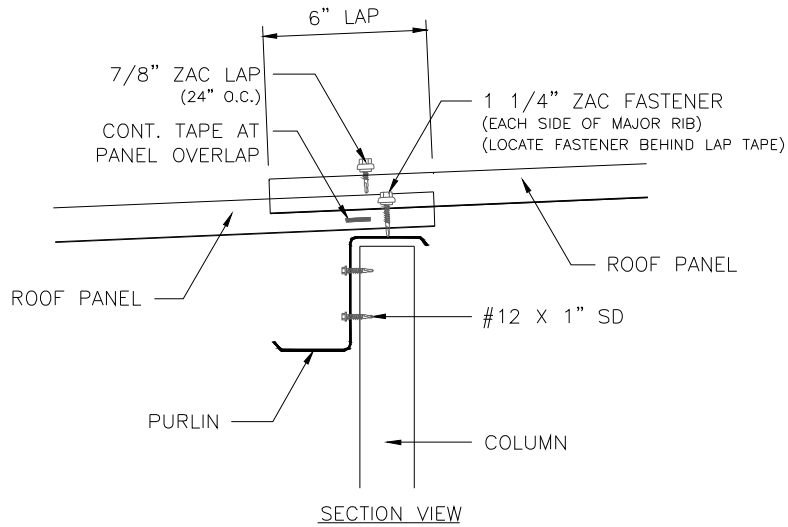

# MISCELLANEOUS DETAILS

Sample Details Only – Refer to Erection Drawings For Job Specific Details

## RAKE

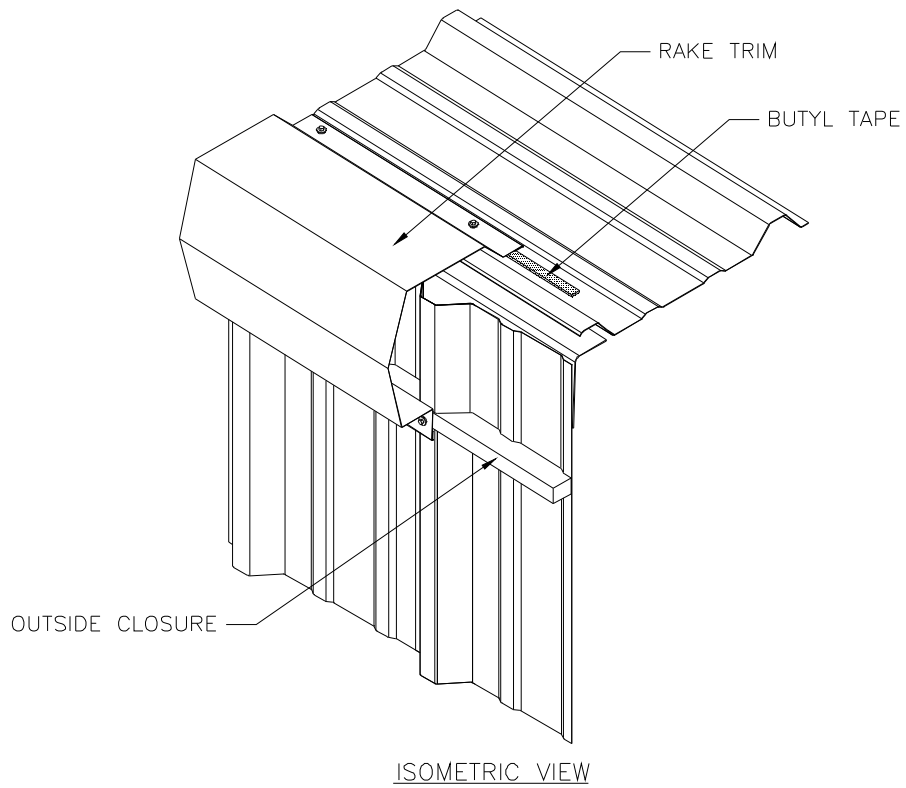
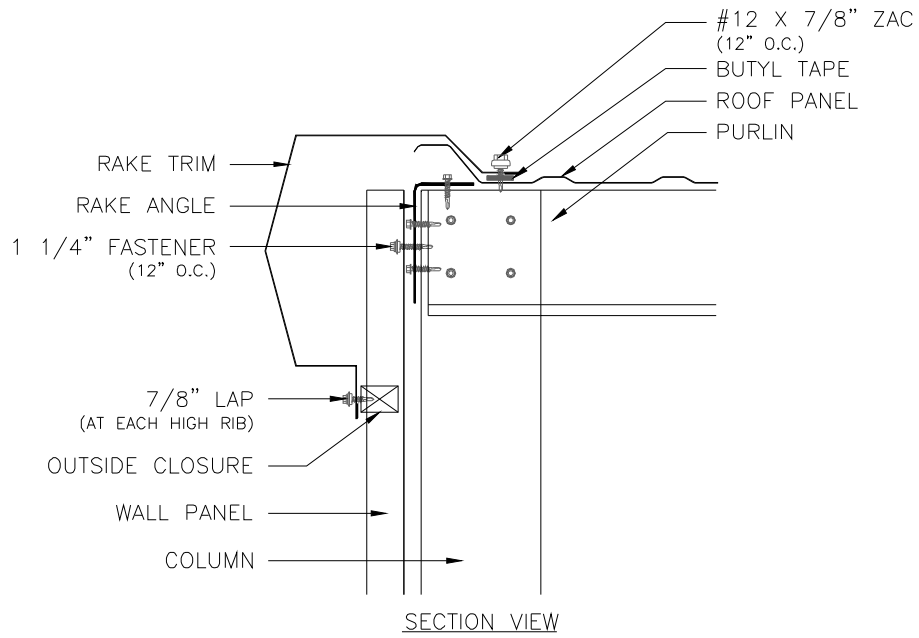

# MISCELLANEOUS DETAILS

Sample Details Only – Refer to Erection Drawings For Job Specific Details

## RAKE END CAP

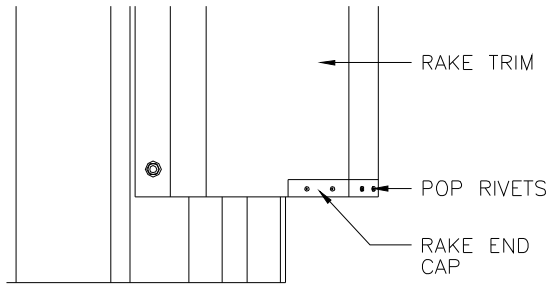

TOP VIEW AT RAKE END CAP

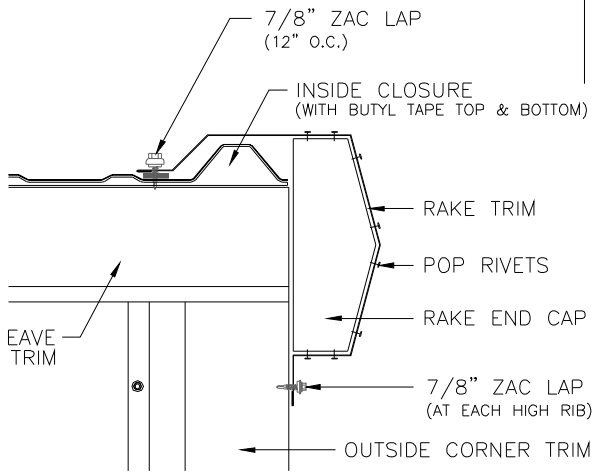

FACE VIEW AT RAKE END CAP

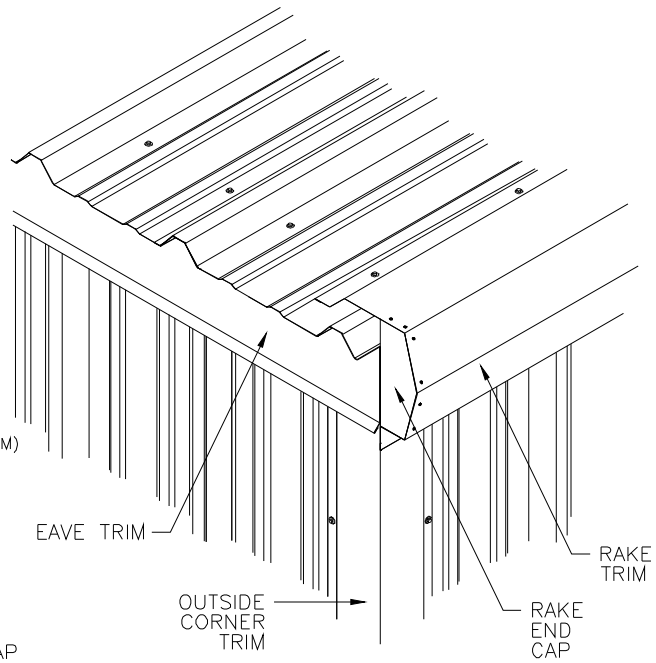

ISOMETRIC VIEW

**MISCELLANEOUS DETAILS**

Sample Details Only – Refer to Erection Drawings For Job Specific Details

**12" STEP CONDITION**

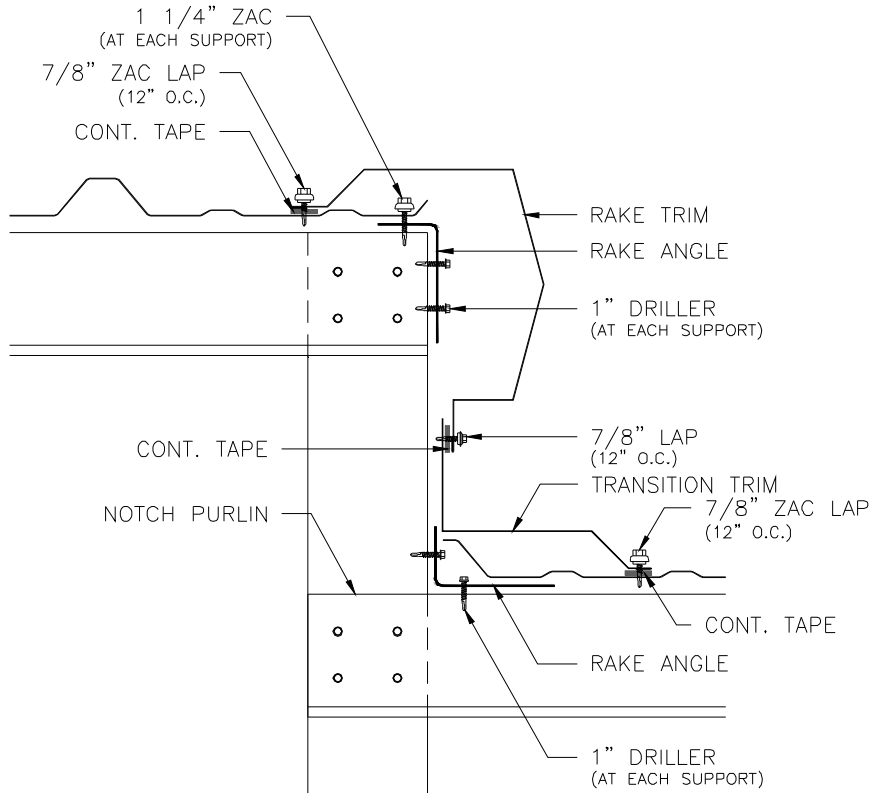

SECTION VIEW

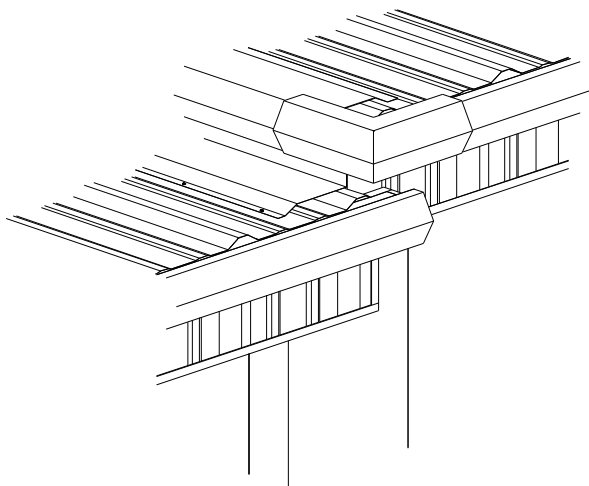

ISOMETRIC VIEW

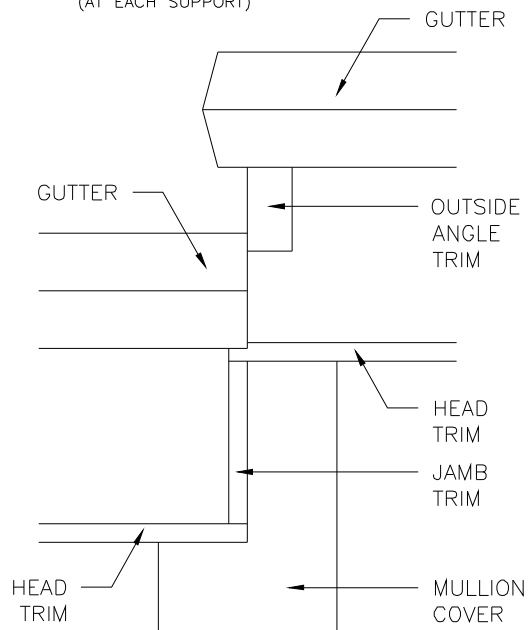

FACE VIEW

**MISCELLANEOUS DETAILS**

Sample Details Only – Refer to Erection Drawings For Job Specific Details

**18" STEP CONDITION**

