

750
mini

JANUS[®] *[International]*



superior product + recognized value

JANUS[®]

[International]

Our Model 750 Certified Wind Load Rated Door is designed and manufactured with durability, quick installation and ease of maintenance in mind. Standard features eliminate the need for options or upgrades. The best door, the best value.

That's the Janus Advantage

FEATURES

The 26 gauge corrugated door curtain is manufactured from full hard galvanized grade 80 steel and coated with Super Durable Polyester paint that is backed by a 40 year film integrity and a 25 year no-fade limited paint warranty. Independently tested in accordance with ASTM-E330, the Model 750 meets the requirements of Standard Building Code, International Building Code and Florida Building Code. Available in sizes through 10'0" x 12'0" and in over 20 different colors.

Opening Widths	Design Windload	
	Pos. PSF	Neg. PSF
Thru 3'0"	35.0	45.0
Over 3'0" thru 6'0"	19.9	24.4
Over 6'0" thru 8'8"	24.4	27.0
Over 8'8" thru 10'0"	19.4	22.7

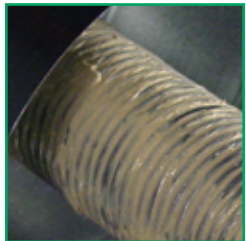

DOOR SPRINGS

During production, each spring is coated with a generous amount of grease that penetrates the pores of the spring with additives, displacing moisture and preventing the formation of rust and corrosion. In addition, this process relieves the friction created between spring coils thereby providing smoother door operation. Finally, the spring and axle assembly is enclosed in a tube to protect them from the elements encountered throughout the life of the door.



RATCHET TENSIONING DEVICE

The Janus ratchet tensioning device supplied as standard equipment on our door offers a simpler method of tensioning while more accurately fine tuning all the springs on the door at the same time. There is no extra hardware required. Eight different positions on the tension wheel allow one to perfectly balance the door every time. There are no pins required to hold the tension on the spring. You simply just click it.



DEAD AXLE & TORQUE TUBE ASSEMBLY

This design, noted for its durability and smoother operation with commercial applications, has now been incorporated into the Janus self storage door. The tube housing protects the springs and strengthens the axle. Eliminating axle push and shift that can occur with a live axle, the dead axle design allows for a straighter travel path of the door curtain in the guides. The biggest feature of this design is that it affords the fine tuning of any spring adjustment to equally affect all springs on the door at the same time.

PACKAGE PROTECTION & SHIPPING

Doors stacked on top of each other in transit are going to shift... unless they can be packaged in a way to minimize the sliding that occurs during that time. Janus has found the way. We suspend each door individually in the crates. Whether they travel down the block or across the country, compaction damages, door abrasion and chatter marks are virtually eliminated.



RADIAL BALL BEARINGS

Janus supplies radial ball bearings at no additional cost. Our permanently lubricated bearings require no maintenance and are guaranteed to last the entire life span of the door.



superior product + recognized value

Three manufacturing facilities located throughout the United States and a team of experienced door experts are available to assist you with any of your door needs.

A three year warranty on workmanship and material.

750 mini



MAGNETIC STAINLESS STEEL LATCH

Our new patent pending mini-latch features a cover plate made from a heavy gauge stainless steel. In addition, the latch cover protects the slide from tampering by completely covering the slide with the exception of a tab used to operate the latch. To further secure the door, the latch's two inch throw with its magnetic properties can be incorporated with the new guide mounted security devices. This versatile design affords the ability for you to utilize padlocks, cylinder locks or both.

All **DRUMS** are fitted with a grease filled, shielded radial ball bearing to contribute to a smoother operation and reduce wear and friction.

Factory installed galvanized reinforced 12 gauge **BRACKETS** are designed to easily snap onto the guides, reducing installation time.

Galvanized, guide mounted **HEAD STOPS** are simple to install and prevents curtain over travel when raising door. Installed through or over guide after curtain is lowered, they provide definite contact with the bottom bar angle.

The **RATCHET SPRING TENSIONER ASSEMBLY** is factory installed on the end of the door axle and allows precise fine tuning of the initial spring tension. Increments of 1/8 turn are possible. Tensioner adjusts both springs equally at the same time from only one end of the door.

Roll formed clear acrylic coated galvanized steel **BOTTOM BAR** reinforced with a 2" x 1-1/2" 11 gauge full width galvanized angle that extends fully into the guides. The PVC bulb astragal provides positive contact with floor. Lift handle(s) installed on exterior side of bottom bar and a non-rotting pull rope is attached to the inside angle. Stop clips are attached to each end of bottom bar angle's horizontal leg.

Oil-tempered helical torsion **SPRINGS** are factory lubricated to minimize friction and corrosion while increasing the spring cycle life. Spring wire conforms to ASTM A 229.

Full width galvanized steel **BARREL** totally encloses the drums, springs and axle. Barrel type construction reduces door sag, eliminates drum dents and improves operation due to an even support of the curtain for the entire width.

Galvanized and pre-painted with long lasting silicone polyester paint, the 26 gauge **CORRUGATED CURTAIN** is roll formed from ASTM A 653 grade 80 full hard steel. This premium steel yields greater door strength and minimized curtain damage. Full height felt tape on back of curtain prevents nesting and reduces paint rubbing. 20 colors are standard with others available on special order. For opening widths over 6'0", 12 gauge windlocks are attached to both ends of curtain.

Roll formed, 18 or 16 gauge galvanized **GUIDES** are fitted with dual polyethylene wear strips to reduce friction and muffle door noises. All guide attachment to jamb is performed through the guides without the addition of clips welded to the back of the guide. This gives a neater appearance, increased strength and aids in tight installations.

Standard stainless steel cover, slide and four attachment bolts are factory installed. The slide exhibits magnetic properties that can be used to activate a guide mounted security sensor. **LATCH** accepts all industry padlocks, including 7/16" diameter shanks. Provision for cylinder lock included.

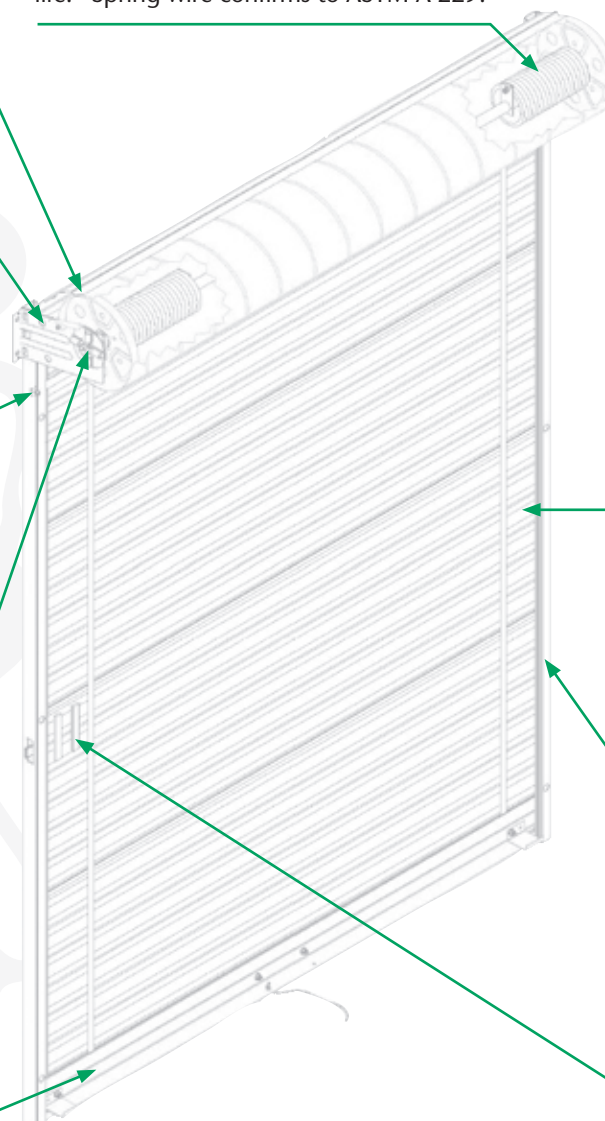

750 mini

superior product + recognized value

GUIDE DETAILS

18 GA GUIDE MOUNTING DETAIL
(for opening widths through 6'0")

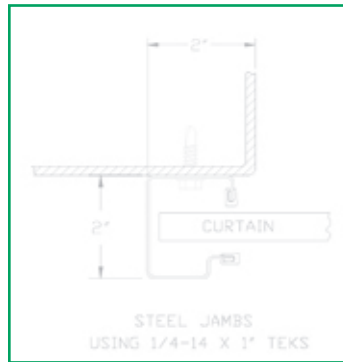
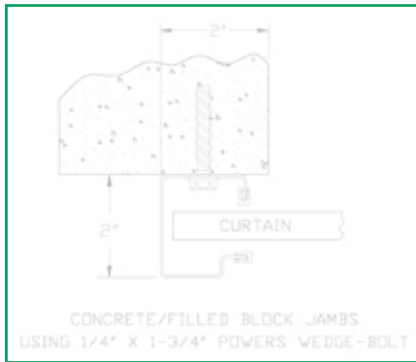

16 GA GUIDE MOUNTING DETAIL
(for opening widths over 6'0" through 10'-0")

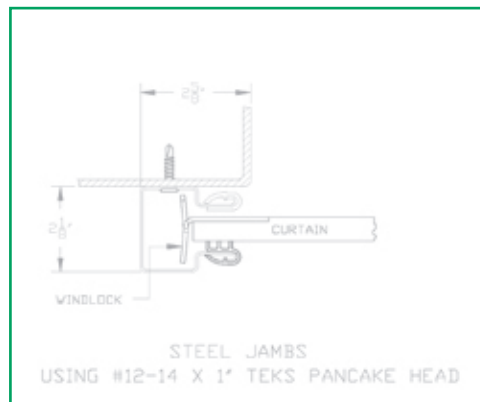

RAIN LIP DETAIL

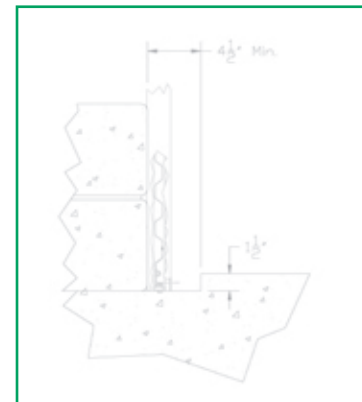

JANUS INTERNATIONAL

{ headquarters }
p.o. box 567
temple, georgia 30179

{ manufacturing facilities }
134 east luke road
temple, georgia 30179

+
1256 brittmore road
houston, texas 77043

+
13374 west peoria avenue
surprise, arizona 85379

+
davy drive; north west industrial estate
peterlee; co durham SR8 2JF united kingdom

{ distribution center }
15330 valley view blvd, suite 5
la mirada, california 90638

PH **1 866 562 2580**
FX **1 770 562 0328**
www.janusintl.com

proud member of:



JANUS INTERNATIONAL CORPORATION

Janus International Corporation specializes in the production of storage facility components, ranging from roll-up doors to self-sustaining hallway systems. The expertise and assistance provided to the customer from designing the unit mix to the final job site punch out is what sets our operation apart from the competition. Our meticulous attention to detail with the prints, manufacturing process, shipping and installation, offers every one of our customers the assurance that they are getting the best product available on the market. It is these qualities and services that keep Janus' customers coming back.

WARRANTY

The Model 750 and its components are warranted to be free of defects in workmanship and material for one year. Our springs are warranted against failure for a period of three years. Our paint warranty guarantees a 40 year film integrity and a 25 year no-fade limited warranty. Please refer to our official warranty for specific details.